



Body 4 Camera User Guide



Models: AX1037, AX1038

Rev: 09 Sep 2025

Axon Enterprise, Inc.
17800 N 85th St
Scottsdale AZ 85255
USA

▲, ▲ AXON, Axon Body, Axon Dock, Axon Evidence, and Axon Fleet are trademarks of Axon Enterprise, Inc., some of which are registered in the US and other countries. For more information, visit www.axon.com/legal. All other trademarks are property of their respective owners.

All rights reserved. ©2025 Axon Enterprise, Inc..

Contents

Introduction and registration	1
Important safety and health information	1
Additional reading	1
Register camera	1
Dock-based registration (recommended)	2
Registration with Axon Device Manager	2
Registration with View XL Standalone mode	4
FAQs	4
Get to know your camera	5
Button actions	5
Accessories and mounts	7
Configure your camera	8
Adjust volume	8
Light setting	9
Camera vibration	9
Programmable buttons	9
Optimized battery capacity	10
End recording confirmation	10
Axon Signal	10
Other settings (admin)	11
Operation	12
Operating modes	12
Turn on the camera and Ready mode (buffering)	12
Start Recording mode (event)	13
Mute audio recording	13
Stealth mode	13
Add markers while recording	14
Illuminate the camera display	14
Battery status	14
Sleep mode	14
On-camera categorization	15
Device pooling	16
Multi-factor authentication (MFA)	17
Watch Me	19
Bi-directional communications	20
System requirements	20
Configuration requirements	20

Use BDC on Respond desktop or mobile	21
Multiple viewers	24
Multiple livestream windows	25
Camera modes	25
Use BDC on the body camera	27
Axon Assistant	30
Admin requirements	30
Assign to body camera button	30
System requirements	31
General FAQs	31
Choose a channel	32
Real-Time Translation channel	32
Use Real-Time Translation	32
Real-Time Translation FAQs	33
General knowledge channel	37
Flex POV camera	38
Flex POV cable connection	38
Connect	39
Manual orientation	39
Automatic orientation	40
Use the camera	40
Priority Upload	42
Start a Priority Upload	42
Use Programmable Button 1	42
Use controls	43
Cancel an upload	44
Error states and edge cases	44
How Priority Upload affects the camera	46
False Signal cancellation	47
Cancel a false Signal activation	47
Automatic Wi-Fi upload	49
Advantages	49
In Axon Evidence	49
Set up a network	49
Enable Automatic Wi-Fi Upload	51
On the camera	51
What triggers Wi-Fi	51
Receive a firmware update over Wi-Fi	52
Disable Wi-Fi Upload on camera	53
Check camera storage	54
Wi-Fi and priority	54

Frequently Asked Questions	54
Video Recall	56
Upload Video Recall recordings	56
Icons, LEDs, and sounds	59
Visual notifications	59
Icons and Triad LEDs while docked	61
Audible and haptic notifications	61
Axon View	63
Pair your camera with a smart device	63
Axon View XL Standalone mode (Windows)	64
Admin settings	65
Video	65
Pre-Event Buffer and Video Recall	65
Watermark	66
Audio	66
Lights	66
Location	66
Axon Respond	67
Evidence upload	67
Axon Signal	67
App support	68
Battery	68
Registration	68
Firmware download	69
User permissions and mute configuration	69
Programmable buttons	69
Device management	70
Button confirmation	70
Care and maintenance	71
Clean the camera	71
Charge the battery	71
Charge without a dock	72
Internal clock	72
Update firmware	72
Moisture	72
Camera storage	73
Troubleshooting	74
General FAQs	74
Axon Dock FAQs	77
Camera registration FAQs	78

ADM error codes	79
View camera information on the display	80
Technical information	81
Technical support	81
Warranty	81
Warnings	81
Radio waves	82
FCC compliance statement	82
ISED Canada compliance statement	83
Declaration of conformity and EU compliance statement	84
Compliance marks	84

Introduction and registration

Axon Body 4 is a body-worn camera system for use in tough environmental conditions encountered by law enforcement, corrections, military, and security personnel. The camera records events for secure storage, retrieval, and analysis on Axon Evidence or Axon Evidence Local. The Axon View app lets you review footage on a smart device prior to uploading. Axon Body 4 is a fully connected device with livestreaming and geolocation capabilities for real-time monitoring in the field.

Important safety and health information

Read, understand, and follow all warnings and instructions before using this product. The most up-to-date warnings and instructions are available at www.axon.com.

Additional reading

This manual discusses how to operate the camera. Other manuals cover additional aspects of the camera system. These documents are available at help.axon.com.

For details on working with uploaded videos and managing cameras, including inventory management and organization-wide settings, see the [Axon Evidence User and Administrator Reference Guide](#).

For details on installing and setting up the dock to transfer information and recharge your camera, see the **Axon Dock** section (or PDF) on your camera's [product page](#) at my.Axon.

For instructions on using Axon cameras with a smart device, see the Axon View for Devices User Manual for [Android](#) or [iOS](#).

Links to [Axon Academy](#) training videos appear in relevant topics of this guide, including how to register for and use the Axon Evidence website, configure settings, assign personnel to cameras, recharge your camera, and transfer video to a computer.

Register camera

Cameras must be registered by your organization before they can be assigned to users. Additionally, you should adjust the organization-wide camera settings in Axon Evidence before assigning cameras to users.

Registering with Axon Device Manager (ADM) requires:

- ADM installed on an appropriate device. If you already have ADM installed, ensure you have v3.0.3 (Android) or v2.0.3 (iOS) or higher installed.

Note

You must have device management permissions to use ADM. If you aren't sure if you have permissions to use ADM, contact an Axon Evidence administrator.

- A Body 4 Dock connected to power and the internet (green ■ LED visible on the WAN port).

Watch the following videos for instructions on registering and deregistering Axon Body 4 cameras.

[Register Axon Body 4 Cameras](#)

[Deregister Axon Body 4 Cameras](#)

Dock-based registration (recommended)

This section describes how to register your camera using the camera dock.

1. In Axon Evidence under Axon Body 4 settings, turn on **Automatic Camera Registration**.
2. Register Axon Body 4 Docks to your agency using the Axon Device Manager app.
3. Place unregistered cameras in any Axon Body 4 Dock registered to your agency.
4. Follow the on-screen instructions to register your camera.

Successfully registered cameras can be charged and assigned to users.

For a complete discussion of your Axon Dock, including installation, see the separate [Axon Dock User Guide](#).

Watch this [video](#) for an overview of docking Body 4 cameras.

Registration with Axon Device Manager

This section describes how to register your camera using [Axon Device Manager](#) (ADM) and the camera dock. Adjust the organization-wide camera settings in Axon Evidence in the Admin section prior to assigning. This requires [device management permissions](#).

You can register up to 100 cameras at once if you have an Axon Dock for each camera. You must keep your mobile device with ADM within 30 feet of all the cameras.

1. Ensure the **Automatic Camera Registration** setting is turned off in Axon Evidence.
2. Press **Power** until you feel a short vibration.
3. Place the camera in a networked dock.
4. Log into ADM and tap **Settings** .

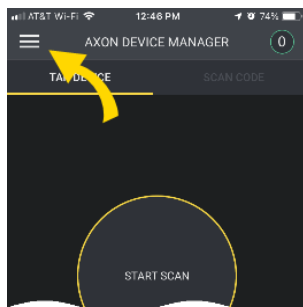

5. Go to Registration, select **Devices**, then your camera.

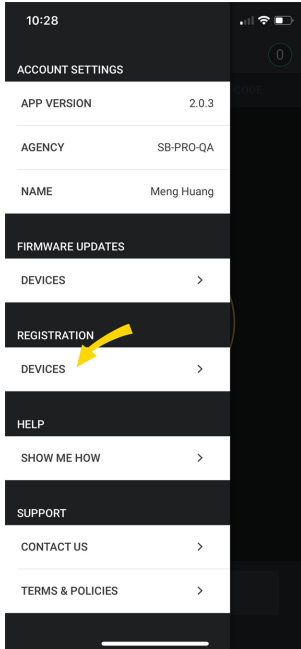

6. Review the device registration setup and tap **Next** **NEXT** to move to the next screen. Tap **Start Scan** **START SCAN** to start the registration process.

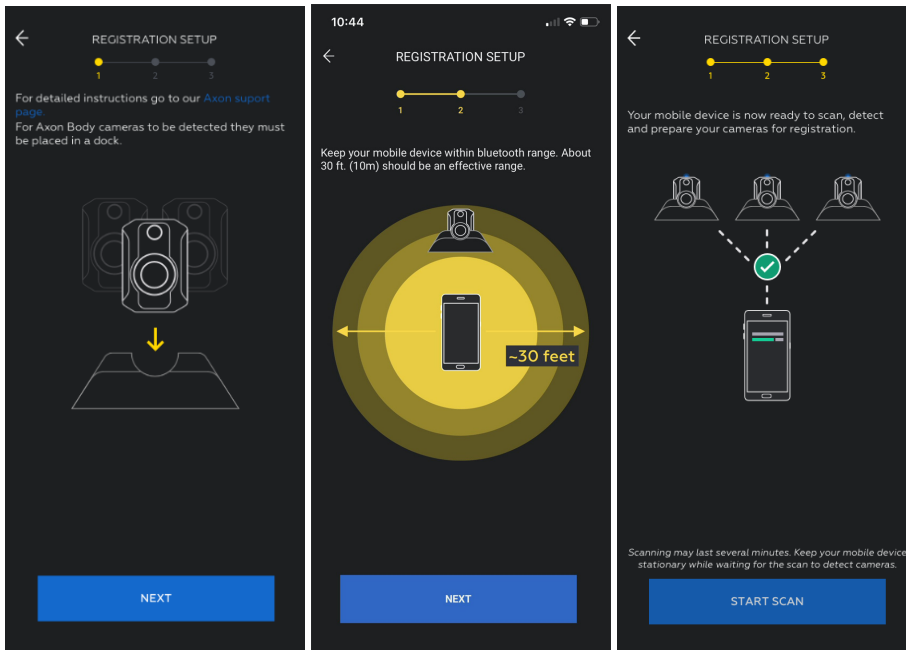

7. ADM detects and prepares unregistered cameras. The number of detected and prepared cameras appears at the top of the ADM screen.
 - Press **Select** (between the volume buttons) on each camera to proceed with the registration.
 - If successful, the display shows **NOT ASSIGNED** to indicate the camera is ready to be assigned to a user.

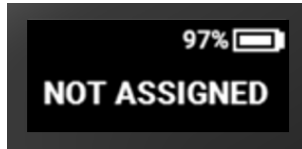

8. When you have registered all the detected cameras, select **Finish**. ADM shows a list of camera serial numbers that have been registered during this session.

Successfully registered cameras can be charged and assigned to users.

Registration with View XL Standalone mode

This section describes how to register your camera using View XL Standalone mode. Registration requires:

- View XL Version v1.17 or later installed on a Windows computer
 - A camera with USB-C cable
1. Launch View XL and enter your agency Axon Evidence URL.
 2. Sign in using your Axon Evidence credentials.
 3. Select **Launch Standalone Mode**.
 4. Connect your camera to View XL using a USB-C cable.
 5. Follow the on-screen instructions to complete the registration process and assign the camera to an officer.

FAQs

For camera registration FAQs, including error codes when registering through ADM, see [Camera registration](#) in Troubleshooting on page 78.

Get to know your camera

Button actions

There are several buttons and features that perform as described below.

Watch this [video](#) for an overview of Body 4 button layout and functions.

Front view

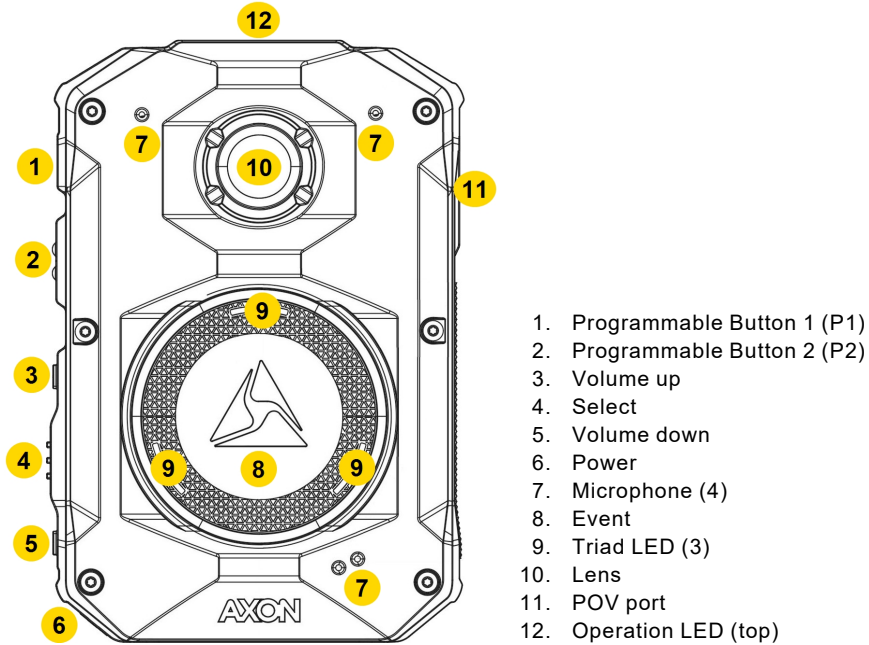

Action	Button Presses
Lights	Press Volume Up ▲ for three second, then tap to toggle modes
Marker, add	Press Select while recording
Menus	Double-press Select
Mute on/off	Press Select for three seconds while recording to mute, double-press Event to unmute
Pairing	Press Event + Select simultaneously
Power off	Press Power for three seconds
Power on	Press Power until short vibration
Programmable Button 1	Double-press Programmable Button 1 (default: Watch Me)

Action	Button Presses
Programmable Button 2	Single-press or long-press Programmable Button 2 , depending on how device behavior is set
Recording start	Double-press Event
Recording stop	Press Event for three seconds
Sleep mode, enter	Press Power then Select to confirm
Sleep mode, exit	Press Power or start a recording
Stealth mode, enter	Press Volume Down for three seconds*
Stealth mode, exit	Press Volume Up ▲ or Volume Down ▼ for three seconds*
Volume, speaker	Press Volume Up ▲ or Volume Down ▼

* The camera remembers the previous volume and light settings when exiting Stealth mode.

For details on screen icons and meanings of both the top Operation and front Triad LEDs, see [Icons, LEDs, and sounds](#) on page 59.

POV Connector Port – Used to connect the POV and body camera together via the POV Cable. All Axon Body 4 Cameras ship with a plastic cover over the port. If a camera will not be using the POV, leave this cover on to protect the port.

Top view

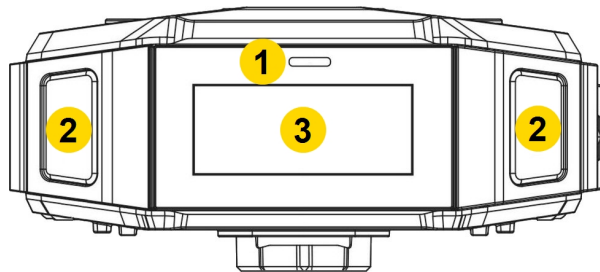

- 1. Operation LED
- 2. Speaker (2)
- 3. Display

Camera Display – Shows information on camera status and activity. Different information appears depending on if the camera is in the field and in an Axon Dock. Some icons may not be active at your organization. The display is divided into a Status Bar and Activity Area.



- 1. Status Bar
- 2. Activity Area

For details on all the icons that may display both in the field and during dock charging, see [Icons, LEDs, and sounds](#) on page 59.

Bottom view

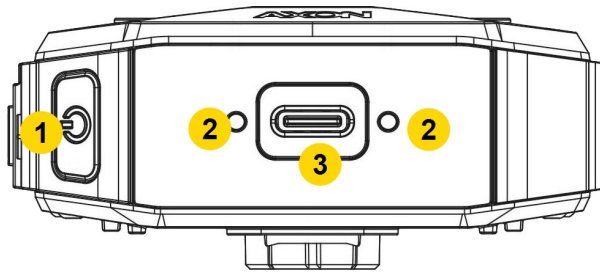

1. Power
2. Magnetic charger port (2)
3. USB-C connector

- **USB-C connector** – Used for data transfer and charging when placed in an Axon Dock.
- **Power button** – Used to turn the camera on/off.
- **Magnetic charger port** – Used to connect the magnetic charging cable.

Accessories and mounts

The Body 4 camera works with a variety of Axon mounting systems.

Note

As with any radio frequency or electronic device, Axon recommends to avoid placing the camera directly next to your radio to prevent inadvertent radio activation.

The various mounts that use this system can be used with a wide variety of uniforms to fasten the camera to your shirt, patrol vest, or jacket.

In general, Axon mounting systems consist of the attachment piece (called the key) on the camera and the attachment receiver (called the lock) on the mount. To lock a camera in place, insert the key of the camera into the lock of the mount (the camera will typically be sideways) and turn it 90 degrees counterclockwise (when you are looking straight at the mount). To release the camera from the mount, turn the camera 90 degrees clockwise.

When wearing the camera, you can use the livestreaming feature of the [Axon View](#) app (see page 63) to show the camera's view.

Watch this [video](#) to see different body camera mounting options.

You can find further information on mounting options, including demonstration videos, on my.Axon at [Body-Worn Camera Mounting Options](#).

Configure your camera

During normal operation, the camera uses lights, sounds, and vibrations (haptic feedback) to notify you of the camera status. These indicators and notifications are managed by your organization and can be configured to allow you to change the setting for your assigned camera.

Check with your Axon administrator to learn which configuration settings you can change. In addition to the methods described below, you may also be able to configure some settings from different software applications:

- **Axon View XL** – Download from Axon Evidence under **Help**. For details, see the **View XL Standalone mode** section on your camera's [product page](#).
- **Axon View** – Install on your smart device from your app store, select **Settings** (see [Axon View](#) on page 63). Go to the [Axon View](#) product page or see the Axon View for Devices User Manual for [Android](#) or [iOS](#) for details about using Axon View. Your camera must be turned on and paired with your mobile device.
- **Axon Evidence** – If your role allows access to the Admin menu, select **Admin > Devices and Applications > Axon model**. Settings will update the next time you dock the camera or it connect to approved Wi-Fi (if enabled).

Watch this [video](#) for more information about configuring the lights, sounds, and haptic feedback of your body camera.

Adjust volume

During normal operation, the camera emits beeping sounds, called audio prompts, to notify you of the camera status.

To adjust camera audio prompt volume:

Use camera controls

Use **Volume Up ▲** and **Volume Down ▼** to adjust the volume. The camera provides audio feedback and indicates the volume setting on the camera display as the volume changes.

Use Axon View or View XL

In Settings, tap **Volume** and select the volume level. The camera beeps once at the volume you tapped, or if you tapped Off, the camera is silent.

Light setting

During normal operation, the camera shows camera status using LEDs. For a description of what the different colors indicate, see [Icons, LEDs, and sounds](#) on page 59. Settings or the ability to change them may be restricted by your administrator.

The camera has the following light settings:

- Lights off
- Lights dim
- Lights on
- Lights auto (automatically adjusts lights based on ambient lighting)

To change the brightness of the LEDs:

Use camera controls

Press **Volume Up ▲** for three seconds. When you see the light setting appear on the screen, press **Volume Up ▲** or **Volume Down ▼** to toggle to the desired light setting. The **Lights out** icon  appears on the display if you toggle the lights off.

Use Axon View or View XL

Tap the switch to the right of **Indicator Lights** to change the setting.

Camera vibration

During normal operation, the camera uses vibrations (haptic feedback) to indicate camera status.

Use Axon View or View XL

Tap the switch to the right of **Vibration** to change the setting.

Programmable buttons

The Programmable Buttons feature allows organizations to customize the behavior of Programmable Buttons 1 and 2 (P1 and P2) in Axon Evidence at **Admin > Body 4 > profile > Programmable Buttons**.

P1 options (double-press) include:

- No Function
- Sleep
- Stealth

- Upload Last Video
- Watch Me

P2 options (single- or double-press) include:

- No Function
- Select (for Marker and Mute)
- Audio Mute
- Assistant (double-press)

For a Respond+ agency, the default behavior of P1 is **Watch Me** and P2 is **No Function**.

Optimized battery capacity

If this setting is enabled in the Admin section of Axon Evidence, the camera will only charge to about 90% capacity and display FULL when finished charging instead of 100%. While this will reduce run-time, it will improve long-term battery health and reduce degradation.

Agencies should analyze their battery needs during the first few weeks of deployment and if users don't require the full 100% of battery, enable this setting to improve long-term battery health with only a minor reduction in run-time.

End recording confirmation

This feature prevents unintentional ending of recordings. If enabled, ending a recording will require a secondary confirmation press of **Select**.

- Always – Confirmation always required.
- Auto – Confirmation only required if Event is pressed during a recording.

Axon Signal

This camera is compatible with Axon Signal technology. Your administrator must activate Axon Signal capability prior to use.

When it is active, Axon Signal technology can broadcast a signal that allows your camera to transition from Ready to Recording mode automatically. When your camera starts recording, you will see, hear, and feel all the normal start-recording notifications.

Axon Signal technology transmissions only allow cameras to start recording. Axon Signal technology does not transmit a signal to end recording. The camera must be stopped manually.

Axon Signal technology cannot power an Axon camera on. If the camera is off, it will not record.

Devices equipped with Axon Signal technology have a signal range of approximately 30 feet (9.1 meters) and can be purchased separately from the Axon Body camera.

Other settings (admin)

Your organization's Axon administrator can configure additional settings and functionality (such as video quality and pre-event buffer time) for your camera. The list of options is in [Admin settings](#) on page 65. Check with your Axon administrator for information about which settings and functionality are available for your camera.

Operation

Before operating an Axon Body camera, ensure it is fully charged and properly configured. For details, see [Charge the battery](#) on page 71.

Watch this [video](#) for additional information about operating a Body 4 camera.

Operating modes

This camera has two operating modes:

- Ready (Buffering) – Camera is on and is pre-event buffering
- Recording (Event) – Camera is recording

Turn on the camera and Ready mode (buffering)

Press **Power** until you feel a short vibration. The camera emits two short rising-pitch tones with a long vibration and then enters Ready (Buffering) mode.

When the camera is in Ready mode:

- The camera display shows READY.
- The Operation LED on top of the camera blinks green .
- The camera is capturing video but not recording to permanent memory.

The pre-event buffer is configurable between 0 and 120 seconds, but set at 30 seconds by default.

When Recording (Event) mode is activated, the buffered video captured directly before the event is saved and attached to the event in permanent memory. This feature captures the video of an incident just before a recording begins. The camera does not capture audio within the pre-event buffer by default (but can be set to do so by an admin).

Ready mode starts when the camera is turned on. It does not buffer video when the camera is turned off, in [Sleep mode](#) (see page 14), or docked.

Start Recording mode (event)

1. To begin recording, double-press **Event**. When your camera starts recording, it emits two short tones and two short vibrations and the display shows the recording icon. The camera provides indications it is in Recording mode:
 - The camera display shows STARTING and then the recording icon.
 - The Operation LED on the camera blinks red ■■■■.
 - The camera emits two short tones and two short vibrations every two minutes as a recording reminder.
2. To stop recording and return to Ready mode, press **Event** for three seconds. The camera emits one long tone and vibrates. If **On-camera categorization** is enabled, follow the on-screen instructions to assign a category. The camera display shows SAVING and then READY and the Operation LED blinks green ■■■■.

Mute audio recording

If your organization's administrator has configured your camera to do so, you can mute audio while recording video.

If Static Mute mode is enabled:

1. Press **Select**(between the volume buttons) for three seconds to mute audio capture. The microphone off icon appears on the camera display and the Operation LED blinks blue ■■■■ while the camera is muted.
2. Press **Select** another three seconds to cancel mute.

If Push and Hold Mute mode is enabled:

1. Press **Select** for three seconds and hold to mute audio capture. The microphone off icon appears on the camera display and the Operation LED blinks blue ■■■■ while the camera is muted.
2. Release **Select** to re-enable audio recording.

Stealth mode

Use Stealth mode to turn off the LEDs, sounds (audio prompts), and vibrations (haptic feedback) on your camera. This is useful for both tactical situations and when dealing with members of the public with light/sound sensitivity.

To enter and exit Stealth mode:

Use camera controls

- To enter Stealth mode – Press **Volume Down ▼** for three seconds. The word STEALTH shows briefly on the camera display activity area and an **S** icon appears in the display.

- To exit Stealth mode – Press **Volume Up ▲** or **Volume Down ▼** for three seconds. The **S** icon disappears from the display.

Use Axon View or View XL

Tap the switch to the right of **Stealth mode** to change the setting.

Add markers while recording

Markers are useful for indicating an important event that you want to easily find when replaying the video. The marker is shown when the video is replayed in Axon Evidence and documented in the audit trail.

To add a marker to a video while you are recording, press **Select**. The camera vibrates once.

Illuminate the camera display

In low-light situations, press any camera button to illuminate the camera display for five seconds.

To change light settings, see [Change light settings](#) and [Stealth mode](#) starting on page 13.

Battery status

The battery capacity for your camera appears on the camera display as a percentage. The Operation and Triad LEDs also reflect battery level; see [Icons, LEDs, and sounds](#) on page 59.

Sleep mode

Sleep mode puts the camera in an idle state that disables recording and buffering. While in this state, an automatic activation enabled at your organization will not initiate camera recording.

Note

The ability to use Sleep mode is enabled by your organization Axon Evidence administrator and may not be available at your organization.

Sleep mode is useful for situations where camera users may need momentary privacy. You can enter Sleep mode from the buffering state in less than three seconds, as opposed to turning the camera completely off. Similarly, the camera will exit Sleep mode and enter a buffering or recording state in less than three seconds.

The device audit trail reflects when Sleep mode is entered and exited. While Sleep mode can be used as an alternative to completely powering down the camera during private situations,

it should not be considered a replacement for powering the camera off. Certain background processes are running while the camera is in Sleep mode and the battery still depletes while in this mode, but at a slower rate.

Enter and exit sleep mode

To enter Sleep mode with Power Off Confirmation disabled:

1. Press **Power**.
2. With **Sleep** selected, press **Select** to enter sleep mode.

To enter Sleep mode with Power Off Confirmation enabled:

1. Press **Power**. The default option will be **Sleep**.

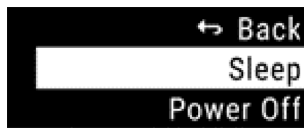

2. Within five seconds, press **Select** to confirm. The display represents Sleep mode with a crescent moon icon.



To exit Sleep mode, either:

- Press **Power** to return the camera to buffering state, or
- Press **Event** once, or
- Press **Event** twice to begin recording.

Watch this [video](#) for an overview of this function.

On-camera categorization

On-camera categorization lets you add categories to videos directly from the camera. To do so, ensure your admin enables the **On Camera Categorization** feature in Axon Evidence at **Admin > Axon Body 4 > your profile** under **Device management**.

Once enabled, after you end a recording, the BWC will prompt you with a list of categories. Scroll or make a selection within 30 seconds or the opportunity to assign a category will expire.

To select a category:

1. Scroll to the appropriate category.
2. Press **Select** (between the volume buttons). A check mark appears next to a selected category.
3. To remove the applied category, press **Select** again.
4. Scroll to and select multiple categories if needed.
5. When finished, hold **Select** to save the selected categories to the recording.

Any selected categories will save automatically if another recording starts while you're assigning them, for example, if triggered by Axon Signal.

You can also tag videos using the [Axon View](#) app, [View XL](#), or Fleet 3 [Dashboard](#), none of which require the **Add Categories** feature.

Device pooling

Cameras shared between users are considered part of a pool. A pooled camera in an Axon Dock is not available for use until evidence is offloaded and its battery reaches 70% of full charge (if your camera requires 90%, leave it in a networked dock for at least eight hours so it can receive a firmware update). Once assigned via the device pooling kiosk, the camera's LED flash rate increases and the screen color inverts to make it easier to find among other cameras still charging. For details on device pooling, contact your Axon representative.

The RFID bulk import capability for device pooling simplifies the management of RFID card assignments by letting you efficiently create multiple simultaneous RFID card-to-user mappings using CSV file imports. The interface centralizes the viewing, searching, and removal of RFID assignments and supports bulk creation, deletion, and management of RFID card-to-user mappings, with options to download backup, template, and error files for streamlined system management and error handling.

Watch these videos for an overview of how to:

- [Check out a device](#)
- [Enable self-checkout for devices](#)
- [Configure the device pooling kiosk](#)

Multi-factor authentication (MFA)

- Note** For MFA to be available on a body camera, your Axon administrator must:
- Enable camera as an MFA method for your agency.
 - Ensure cameras are on the latest firmware.
 - Ensure the camera is assigned to the user.
 - Ensure the camera is not in a lost or stolen state.

Your body camera can function as an MFA device (sometimes called Two-Factor Authentication, or 2FA).

1. Sign into Axon Evidence (or other apps).
2. Select **Body camera** from the MFA select screen.

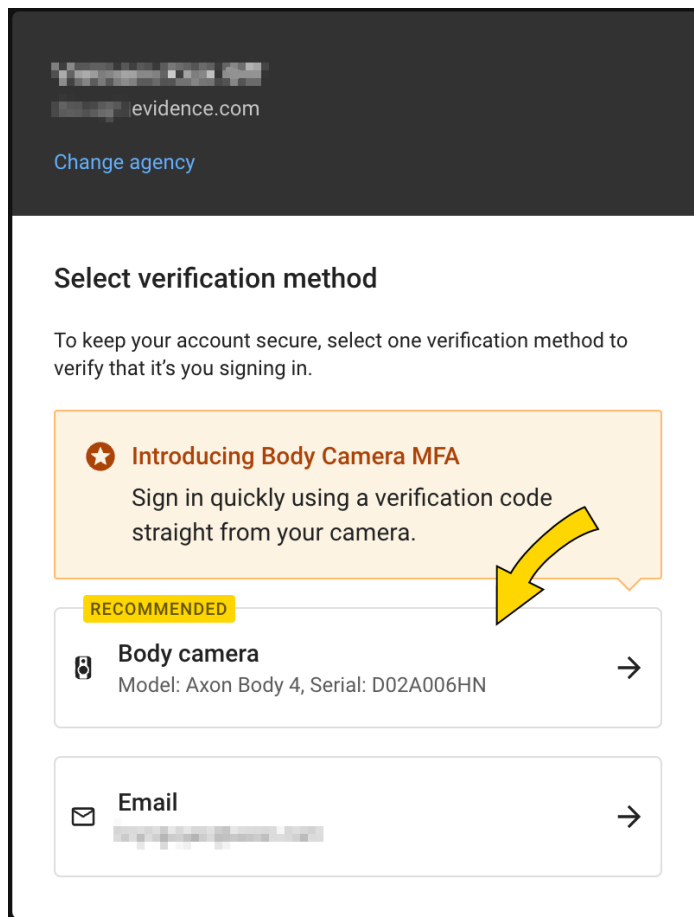

3. On your body camera, double-press Programmable Button 2 (P2) to use the MFA shortcut. Or...

4. Double-press **Select** (between the volume keys) to open the menu, press **Volume down ▼** to reach **Authenticator**, then press **Select**.



5. Use the MFA code displayed to sign in. The progress bar at the bottom shows when the code will refresh.

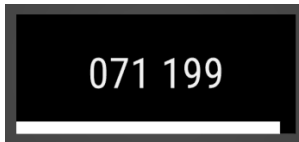

MFA may start midway through a code cycle, depending on when you request it. The camera returns to the main screen after 60 seconds or with any button press.

You can use the shortcut to access the MFA screen while recording unless your agency has assigned it to a different action.

Learn more at [MFA User Guide](#) and (for admins) [MFA Admin Guide](#).

Watch this [video](#) for an overview of this function.

Watch Me

Watch Me gives anyone wearing a Body 4 camera a simple way to request supervisors, command staff, and dispatchers to quickly view their livestream.

Watch this [video](#) for an overview of the Watch Me function.

To request a second pair of eyes, double-press **Programmable Button 1** (the default assignment) to alert Respond users. Supervisors and command staff can tap on the notification or the purple bubble to quickly view the user's livestream and provide real-time assistance.



1. Programmable Button 1

If the camera is buffering, a Watch Me request will start a recording. If the camera is already recording, it will continue recording after the Watch Me request. To cancel a Watch Me request, simply long-press **Event** to end the recording.

[Granular permissions](#) let admins configure Watch Me notifications to work in conjunction with your organization's organizational structure using [Command hierarchy](#). With command hierarchy enabled, select **Only in their command** in the **View BWC locations** user role settings. Given this user role configuration, users assigned this role will only receive notifications from camera wearers under their command in the command hierarchy.

Watch Me requests are only sent to users permitted to view the livestream (they have access to the livestream associated with the request).

Bi-directional communications

Bi-directional communications (BDC) lets dispatchers and command staff talk to Body 4-equipped officers from either the Respond desktop or mobile app. Being able to see, hear, and now communicate with officers brings support teams even closer to the scene—from the safety of their individual locations—to provide even greater support to officers.

During a livestream, authorized dispatchers and command staff can start a conversation with a Body 4-equipped officer from within the Respond desktop or mobile app by pressing the Start call button. The conversation will continue for the duration of the livestream and is hands-free for the officer. Up to 25 Respond viewers can participate in a single conversation. All conversations are recorded and uploaded to Axon Evidence as part of the evidentiary video, just like any other Axon body camera recording.

For instructions on how to use BDC on Body 4, jump down to [Use BDC on the body camera](#).

Watch this [video](#) for an overview of BDC.

System requirements

- Body 4 camera
- Respond+ licensing
- Meet the Axon Web [System requirements](#) for desktop users and mobile app for mobile users
- To use bi-directional communications on desktop, users must have an audio input and output device, such as microphone and speaker or headset

Configuration requirements

- Livestreaming must be [enabled](#) for Body 4 cameras. In Axon Evidence, see the **Admin > Body 4 > profile > Axon Respond** section.
- Dispatchers and command staff must have Axon Evidence credentials and belong to a role with **View BWC Livestreams and Allow Voice Communication** permissions enabled in Axon Evidence at **Admin > Roles & Permissions**.

Use BDC on Respond desktop or mobile

1. Sign in.

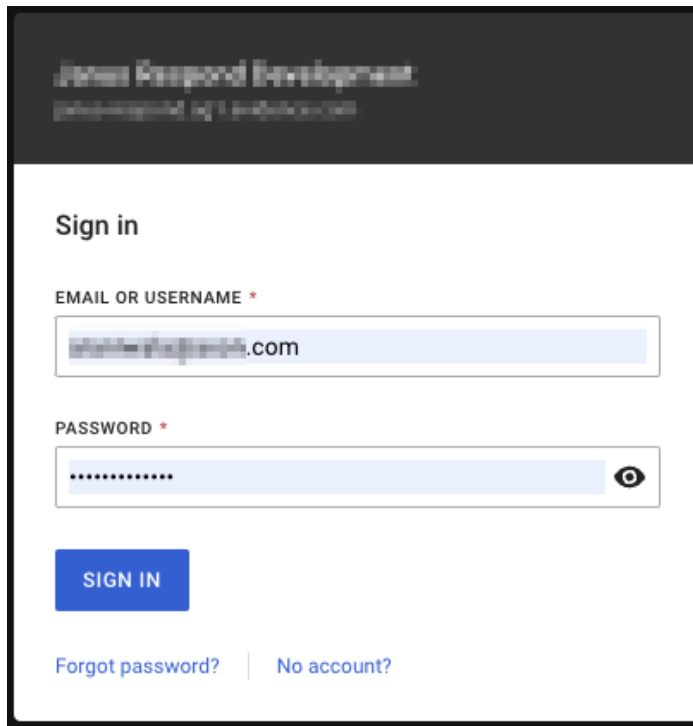

The screenshot shows the sign-in page for Axon Respond Development. At the top, it says "Axon Respond Development" and "Respond Development (v1.0.0) (2020-09-01)". Below this is a "Sign in" section with two input fields: "EMAIL OR USERNAME" containing "johndoe@axon.com" and "PASSWORD" with masked characters and a visibility toggle. A blue "SIGN IN" button is below the fields. At the bottom, there are links for "Forgot password?" and "No account?".

2. Select the **Respond** tab...

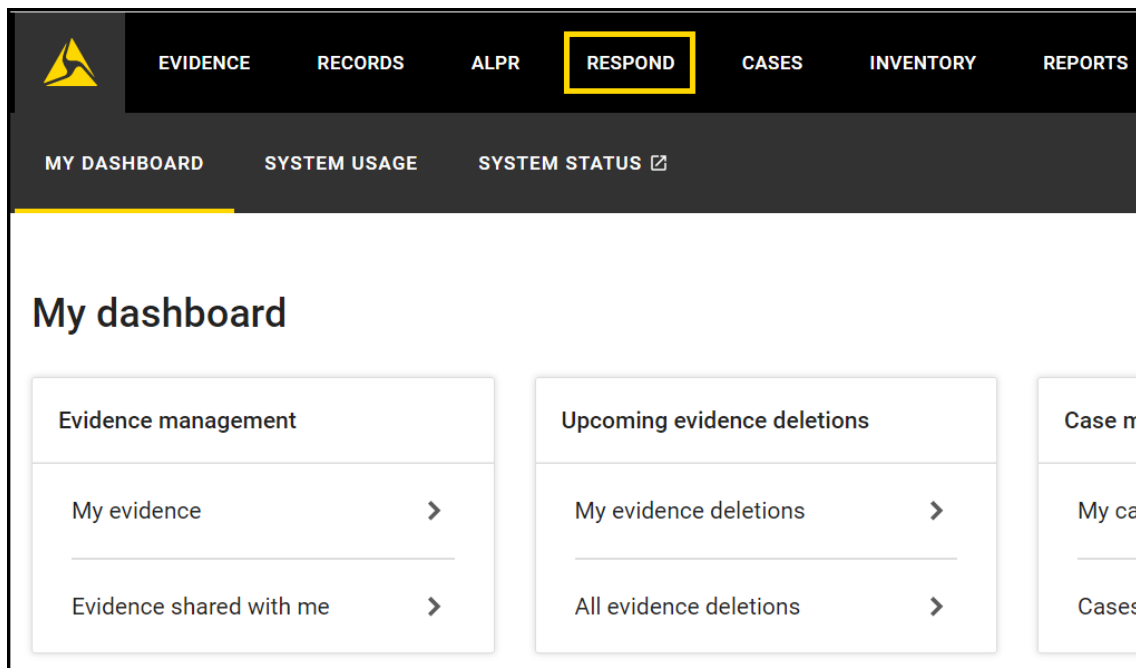

The screenshot shows the Axon Respond desktop dashboard. The top navigation bar includes a logo and tabs for "EVIDENCE", "RECORDS", "ALPR", "RESPOND" (highlighted with a yellow box), "CASES", "INVENTORY", and "REPORTS". Below this is a secondary navigation bar with "MY DASHBOARD", "SYSTEM USAGE", and "SYSTEM STATUS". The main content area is titled "My dashboard" and contains three columns of cards. The first column, "Evidence management", has "My evidence" and "Evidence shared with me". The second column, "Upcoming evidence deletions", has "My evidence deletions" and "All evidence deletions". The third column, "Case m...", has "My ca..." and "Cases".

3. ...to view the Respond map and start a Livestream from a Body 4-equipped officer. The camera must be recording to be livestreamed. Grant microphone access if needed.

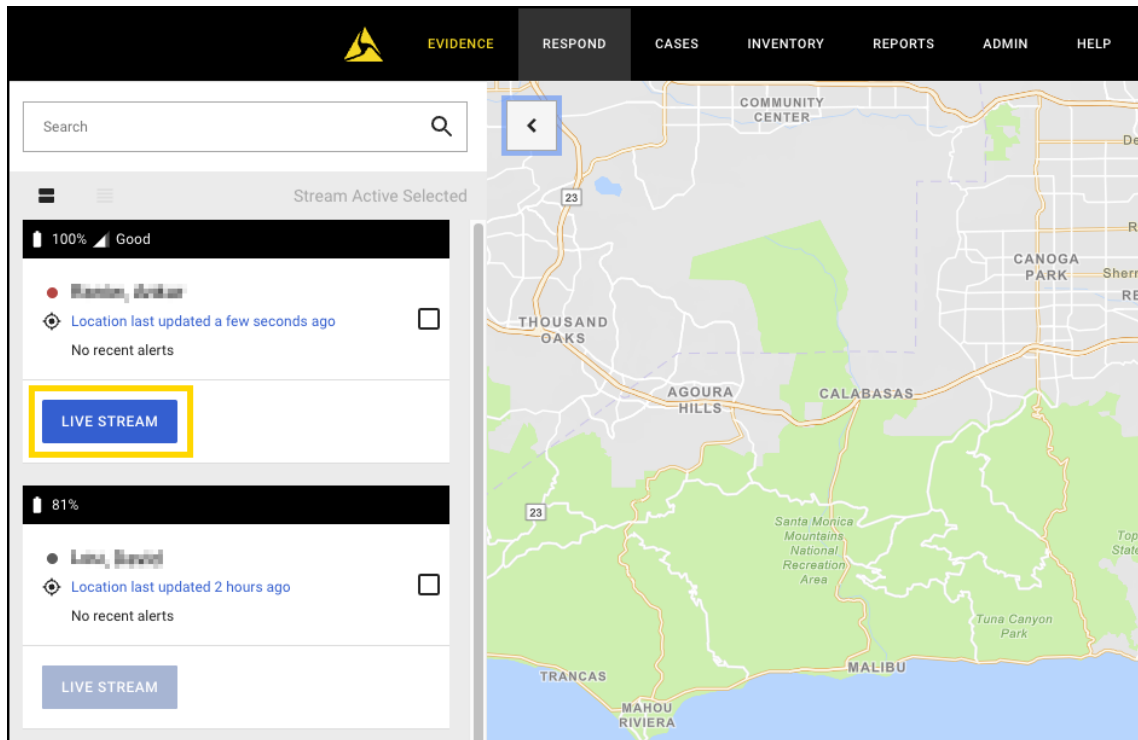

4. Select **Start Live Streaming** on a user's tile.

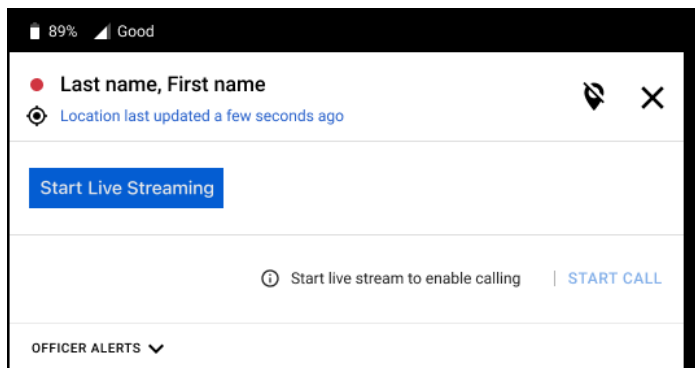

5. Select **Start Call** to start bi-directional communication.

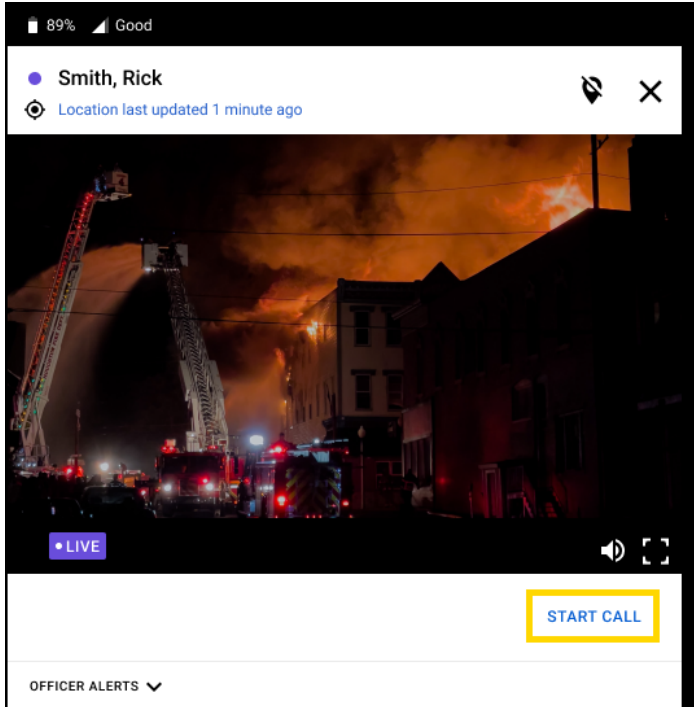

6. Wait to be connected to the Body 4 camera.

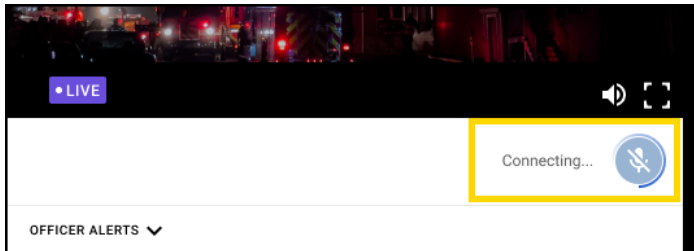

7. Your microphone is muted upon successfully connecting. Press and hold the push-to-talk (PTT) button with your mouse or by holding the space bar on your keyboard. Wait to hear the “go-ahead” tone, which indicates you can start talking.

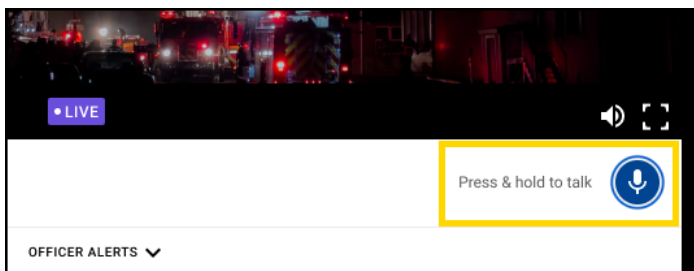

- You may now speak to the Body 4 camera user. Release the mouse (or space bar) when you are done.

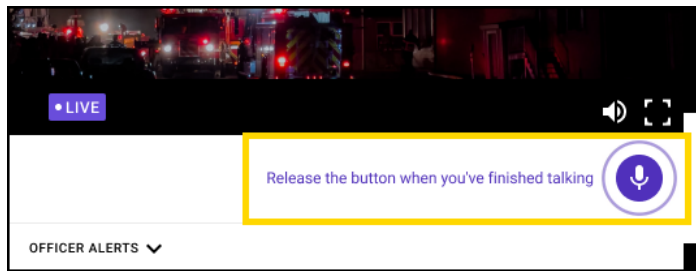

Multiple viewers

Just like livestreaming, bi-directional communications supports up to 25 simultaneous Respond viewers per Body 4 camera. If a conversation is ongoing between a Respond viewer and camera user, any Respond viewer who opens the livestream to that camera will automatically be added to the conversation. Similarly, if multiple Respond viewers are watching a livestream and one viewer starts a call, all other viewers are automatically added to that conversation.

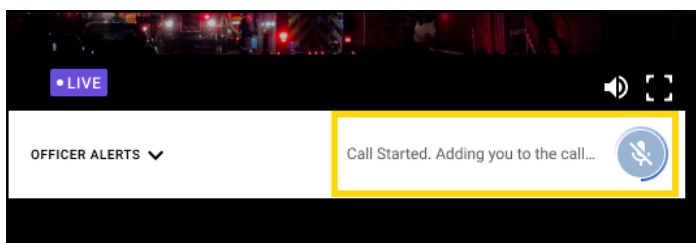
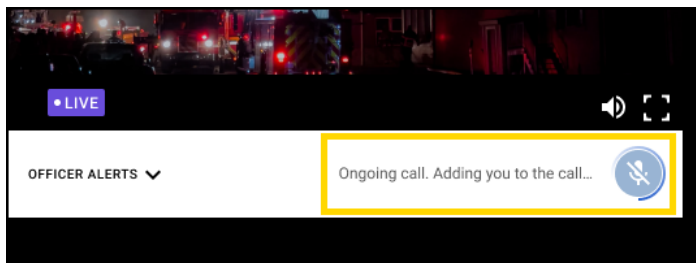

Once the Respond viewer is added, the card will update to show the total number of viewers in the conversation.

Multiple livestream windows

If multiple camera livestream windows are open, you may start or join a conversation for the livestream in the foreground. Shifting from one camera window to another will drop you from the first conversation. Audio will start playing from the window in the foreground.

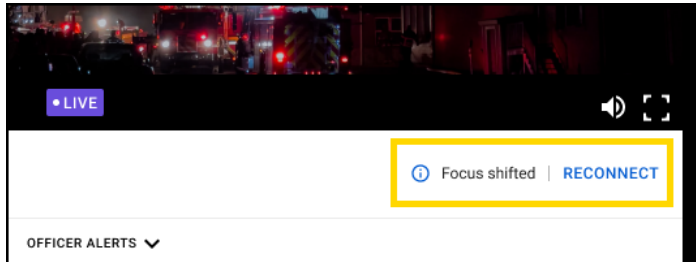

Camera modes

The Body 4 camera may enter modes or conditions that make it unavailable for bi-directional communications. When this happens, Axon Respond will update to prevent you from talking. Here are two camera modes that do not allow bi-directional communications and how they are display in Axon Respond:

Stealth mode

When the Body 4 camera enters stealth mode, its speaker becomes muted and, therefore, the Respond user is not allowed to talk.

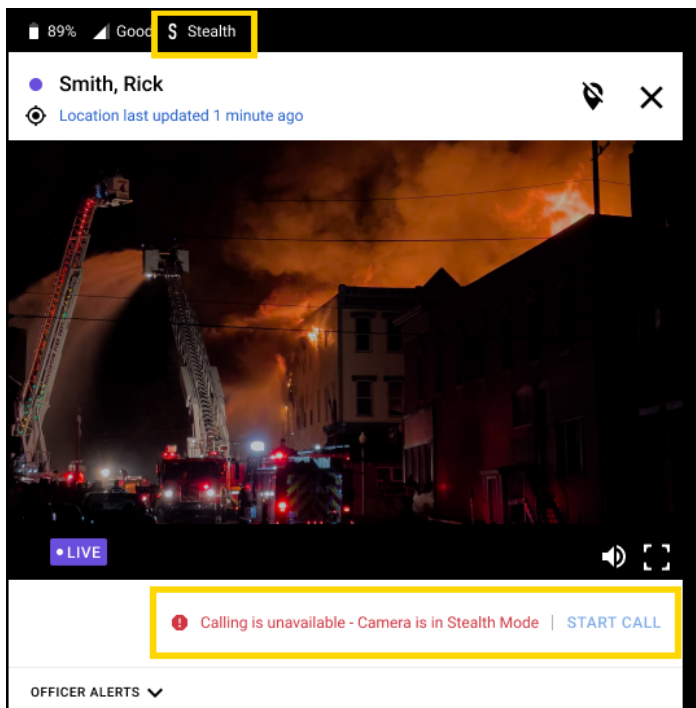

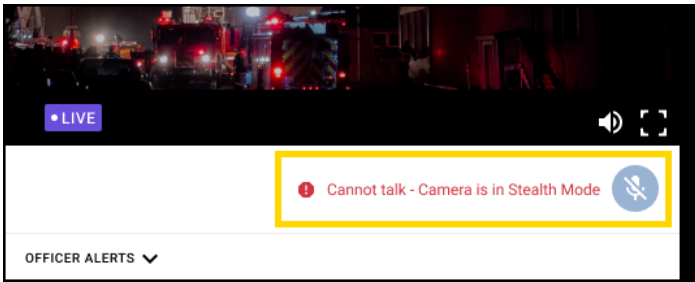

Speaker muted

When the Body 4 camera's speaker volume is muted, the Respond user is not allowed to talk.

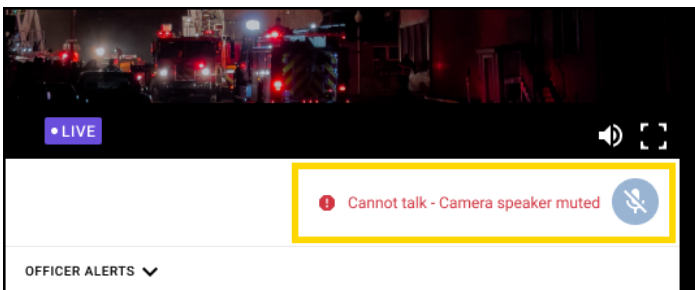
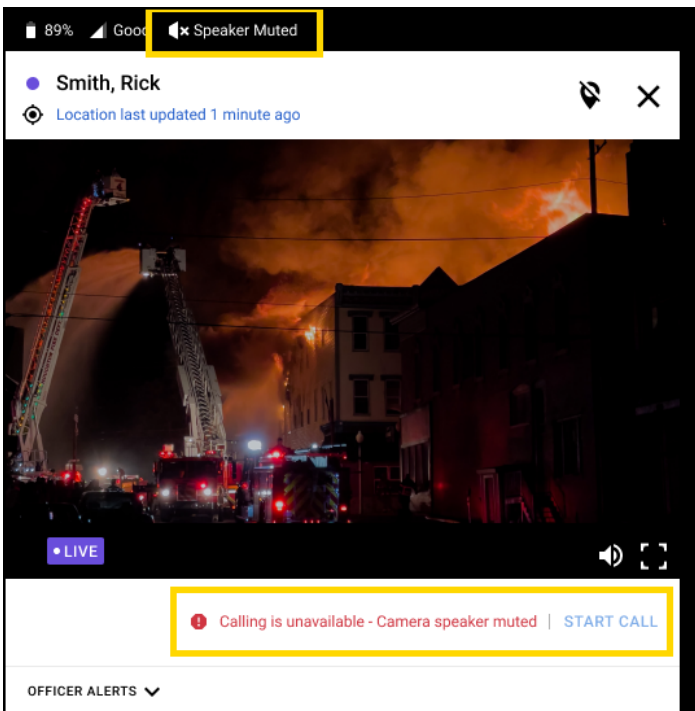

Microphone muted

When the camera's microphone is muted, you will not hear any audio. If this happens, any Respond viewers in the conversation may continue to talk to each other and the camera user will still hear them, but they will not hear the camera user.

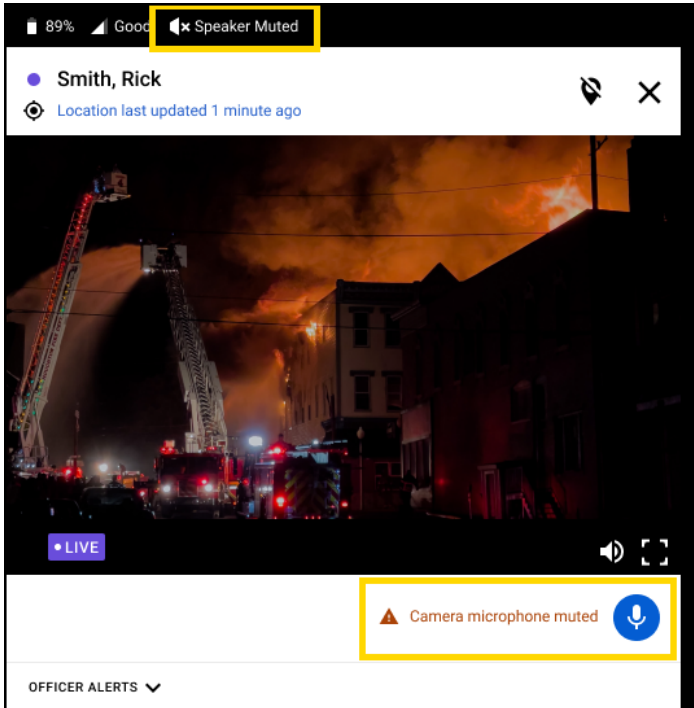

Use BDC on the body camera

While your Body 4 camera is livestreaming, a LIVE icon appears on the display:



If a Respond user starts a conversation with you, the camera will vibrate, play a tone, and the display will briefly show COMMS OPEN to inform you that someone has started a conversation and audio can start playing from the camera's speaker.



Once connected, the display will update to show the total number of Respond users in the conversation:



The conversation ends when you end the recording or when all users have closed the livestream. The camera will vibrate, play a tone, and the display will briefly show COMMS CLOSED.



Respond viewer joins or leaves

When a Respond user joins or leaves the conversation, the camera will vibrate, play a tone, and the display will indicate the total number of participants. If no Respond viewers remain, the conversation ends.

Microphone control

When you mute the camera's microphone while recording, it also prevents Respond users from hearing camera audio.



Axon Assistant

Axon Assistant is an AI assistant accessible through a push-to-talk interface on your body camera. The Assistant provides several channels, each with different capabilities.

To select a channel, double-press Programmable Button 2 (P2) to connect to Axon Assistant, then double-press again to cycle through enabled channels. Once connected, the camera displays the selected channel and audibly states the name.

Admin requirements

Assign to body camera button

Once Axon Assistant is enabled for your organization, assign it to your cameras (Body 4 in this example):

1. Go to Body 4 settings in Axon Evidence at **Admin > Body Camera > Axon Body 4 > profile**.
2. Under **Programmable Buttons**, open the dropdown for Programmable Button 2 and select **Assistant (double-pressed)**.

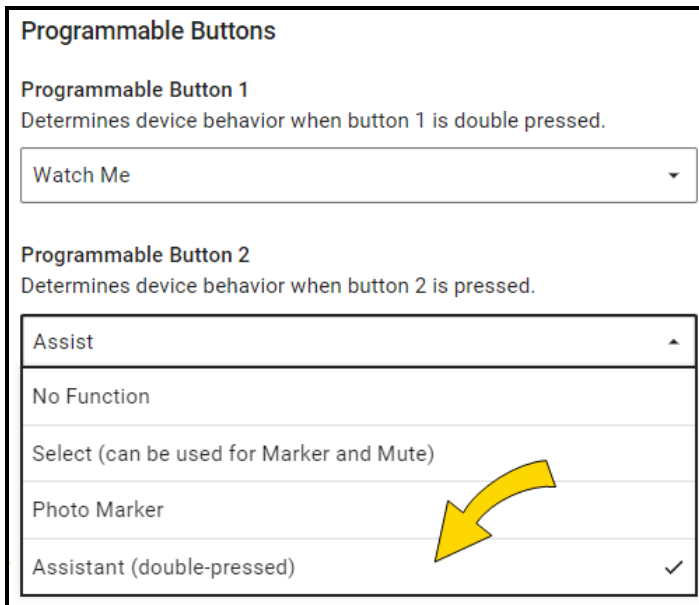

Programmable Buttons

Programmable Button 1
Determines device behavior when button 1 is double pressed.

Watch Me

Programmable Button 2
Determines device behavior when button 2 is pressed.

Assist

No Function

Select (can be used for Marker and Mute)

Photo Marker

Assistant (double-pressed) ✓

3. Optional: to enable the Assistant only for select users, create different device settings profiles. For example, one profile can have the Assistant assigned to P2 while another profile assigns Photo Marker. Then assign different roles to the appropriate profile (at

the top of the settings page for that profile, shown below) to determine which users receive which P2 behavior. Learn more at [Role-based settings - Devices](#) on my.axon.

Axon Body 4 Camera Settings AB4 Device Profile - AB4 Default

Adjust the settings of Axon Body 4 cameras with the current Device Settings Profile. To view and manage additional settings profiles that can be applied to different user roles, visit the [AB4 Settings Profiles](#)

PROFILE NAME	ASSIGNED ROLES
AB4 Default	All available roles ▼

AB4 cameras of all users with the selected roles will inherit the settings on this page. Roles on the default profile are available to be added to other profiles.

Users who previously used P2 for Select, Marker, or Mute will now use **Select** (between the volume buttons).

System requirements

- Body 4 camera
- Respond, Respond+, or Device Connectivity licensing
- LTE or trusted Wi-Fi connection

General FAQs

Can other Axon body cameras use Axon Assistant?

Only Axon Body 4 supports Axon Assistant at this time.

Does using Axon Assistant raise any data privacy concerns?

No. No data is shared back to providers of foundational models and all data remains within Axon's secure cloud environment at all times.

How does Axon Assistant affect battery life?

Using Assistant occasionally during a normal shift has minimal effect on battery life.

Can I use my voice to activate Assistant instead of pressing P2?

No. Axon Assistant is a push-to-talk interface, like using a radio or walkie-talkie. It requires a press-and-hold of P2 while capturing speech and a release when done.

Choose a channel

To select a channel, double-press Programmable Button 2 (P2) to connect to Axon Assistant, then promptly double-press again to cycle through enabled channels. The following Axon Assistant channels are available:

Channel	Description
Real-Time Translation (next section)	RTT is push-to-talk voice translation directly on the body camera. Communicate with speakers of other languages without waiting for human interpreters.
General Knowledge (see page 37)	<p>Ask about facts, definitions, and calculations useful in the field, such as:</p> <ul style="list-style-type: none"> • What are common street names for Xanax? • What does USDOT hazard 1090 mean? • What is 15% of 198? <p>Answers are AI-generated from open sources; verify before critical use.</p>

Availability differs by worldwide region, with initial releases beginning mid 2025.

Real-Time Translation channel

Real-Time Translation (RTT) enables two people who speak different languages to communicate with each another. Speech in your language is translated to and spoken in a foreign language, and the verbal reply in that language is translated to and spoken in yours. In the future, the Assistant will gain additional base languages beyond English.

At the start of translation, the camera automatically begins recording. This ensures both sides of a conversation are recorded for a human interpreter to later produce a certified translation, if required.

For instructions on how to use translation on a Body 4, jump down to [Use Real-Time Translation](#) on page 32.

Watch this [video](#) for an overview of using Real-Time Translation on Axon Body 4.

Use Real-Time Translation

The Real-Time Translation channel provides some of these instructions audibly during use.

1. Turn on the camera and once ready to record, wait 10 seconds for it to get fully online.
2. Double-press Programmable Button 2 (P2) to start connecting, during which the camera will chirp a few times.
3. Once connected to Axon Assistant, double-press again promptly as needed to cycle through channels until you hear "Translation". Once connected, it announces "Translation", displays **Translation** on the screen, and provides verbal instructions.

4. Hold P2 and listen for the audible tone indicating audio will be captured. The camera starts recording.
5. Set a language:
 - a. If you know what language you need, set it manually by saying “Translate to [language name]”. Release P2.
 - b. If you don't know what language you need, say “Auto-Detect”, have the foreign language speaker say a few full sentences, and release P2. After a brief pause, the camera announces the language identified and translates the statement to your language.
 - If the Assistant can't determine the language, repeat (b), but have them speak for a longer period of time.
 - c. To restart with a different language, double-press P2 and start at step (a).
6. To continue the conversation in either direction, hold P2 to record speech, then release to translate.

If you stop recording while the RTT channel is active, the translation function remains active. The channel disconnects after a period of inactivity; there's nothing to turn off.

Real-Time Translation FAQs

- General (below)
- [Language support](#) (see page 34)
- [Security and privacy](#) (see page 35)
- [Camera considerations](#) (see page 36)
- [Respond and Fusus](#)

General

When should I use this channel?

Real-Time Translation is for everyday encounters, such as traffic stops, minor incident reports, and public event security. While it is not certified for taking witness statements or use in situations where extreme accuracy is critical (such as prescribing medication), using RTT automatically starts camera recording, and that recording can be taken to a certified human interpreter if needed.

Are translations included in Draft One reports?

Yes. As with all Draft One reports, review and certify generated contents before submitting.

Does RTT require any other Axon products?

See [System requirements](#) on page 31.

Language support

What languages does RTT support?

Users speaking different languages can understand each others' "main intent" (at a minimum) in the vast majority of cases for the following 50+ languages:

Afrikaans	Estonian	Kazakh	Russian
Arabic	Finnish	Korean	Serbian
Armenian	French	Latvian	Slovak
Azerbaijani	Galician	Lithuanian	Slovenian
Belarusian	German	Macedonian	Spanish
Bosnian	Greek	Malay	Swahili
Bulgarian	Hebrew	Marathi	Swedish
Catalan	Hindi	Maori	Tagalog
Chinese	Hungarian	Nepali	Tamil
Croatian	Icelandic	Norwegian	Thai
Czech	Indonesian	Persian	Turkish
Danish	Italian	Polish	Ukrainian
Dutch	Japanese	Portuguese	Urdu
English	Kannada	Romanian	Vietnamese
			Welsh

Does RTT support "mixed" languages like Spanish-English or Chinese-English?

The service will do its best to translate languages that are a combination of two, but results will vary depending on the languages involved.

Does RTT translate sign language?

No. RTT requires audio input.

How do I switch languages?

To change languages, double-press P2 and set a new language by saying "Translate to <language> or "Auto Detect" again. Also see Step 5 in [Use translation](#) on page 32.

How does RTT handle profanity and slang?

All voice input is translated with the goal to ensure both users understand the main intent of the communication. This includes slang and profanity, though results will vary by language.

Can I use Real-Time Translation while offline?

No. RTT requires a connection to LTE or a trusted Wi-Fi network.

Does RTT work in noisy environments?

RTT works best in environments where two people can have a conversation without needing to raise their voices. Translations may be difficult to hear in noisy settings.

Is RTT usable in prosecution?

No. Real-Time Translation has not yet been tested against relevant translation standards required for use in court. Translation output should **not be used** as evidence for prosecution or in court unless human-certified (although the body camera video is still applicable).

Security and privacy

Are translations stored in Axon Evidence?

Yes. Starting translation also starts a recording, which captures audio from the interaction.

Are translations auto-transcribed in Axon Evidence?

If you have Auto-Transcription enabled, yes. Foreign languages transcribe for a limited (but growing) set of languages.

Is RTT always listening to conversations?

No. Translation only captures audio input while the P2 button is held down.

What agency information does RTT retain and for how long?

Retained information includes anonymized metadata about the body camera (such as device ID) and timestamps for when and how long translation occurred. This information is retained for one year through secure logging and metrics. No transcripts or audio recordings of translations are stored other than a normal body camera recording for upload to Axon Evidence.

How do members of the public know a translation tool is in use?

While some members of the public will realize the camera is being used for translation, others may not. After setting the translation language, we recommend advising the public that the camera is being used for translation and confirming that they understand before proceeding.

Camera considerations

Can I replay prior translations on my camera?

No. Ask the speaker to repeat their statement or review it later in Axon Evidence.

Can I customize the camera voice?

No. The voice is fixed for each geographical region.

Can the camera translate silently or through a headset without people knowing it?

No. Translation only occurs out loud to facilitate active conversation.

Does translation incur additional data charges?

No. Data usage for translation uses existing camera connectivity.

Respond and Fusus

What do Fusus livestream viewers experience when an officer uses translation?

Fusus livestream viewers hear the same audio input and output as the user, including audible notification tones, voice inputs for translation, and translations emitted by the device.

General knowledge channel

The General knowledge channel provides some of these instructions verbally during use.

1. Turn on the camera and once ready to record, wait 10 seconds for it to get fully online.
2. Double-press Programmable Button 2 (P2) to start connecting, during which the camera will chirp a few times.
3. Once connected to Axon Assistant, double-press again as needed to cycle through channels until you hear "General knowledge". Once connected, it announces "General knowledge", displays **General knowledge** on the screen, and provides verbal instructions.
4. Hold P2 and listen for the audible tone indicating audio will be captured.
5. Ask your question, then release P2. After a few moments, the channel provides an answer. Questions do not build on each other; each question is a new request.
6. To ask another question, return to step 4.

This channel will disconnect after a period of inactivity; there's nothing to turn off.

Watch this [video](#) for an overview of using General knowledge on Axon Body 4.

Flex POV camera

Axon Body 4 accessories include a new Flex point-of-view (POV) camera that connects to the side USB-C connector. It offers high-quality video and low-light capture from an user's point of view with the same IP67 waterproof rating and no separate charging requirement.

Watch this [video](#) for additional information about using the Flex POV with the Axon Body 4.

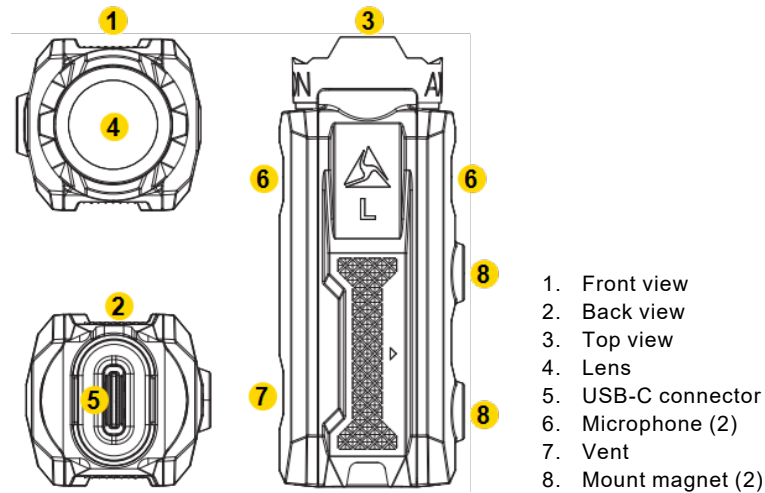

- **Lens** – Avoid touching the lens
- **Vent** – Avoid covering up the air vent with any stickers
- **USB-C Connector** – Connects to a cable leading to the Body 4 Camera
- **Microphone** – Records ambient sound
- **Mount Magnet** – Connects to the POV Mount

Important

Avoid using the Flex POV camera at an indoor firing range as this may damage its microphones.

Flex POV cable connection

The Flex POV camera and the Axon Body 4 Camera work with a purpose-built cable with a smaller, straight connector at one end and a larger, right-angle connector at the other.

Unlock the POV latching mechanism and insert the camera's connector into the connector port with the cable pointing up as shown, then lock it in place by pushing up on the locking mechanism until it's flush with the rest of the connector.

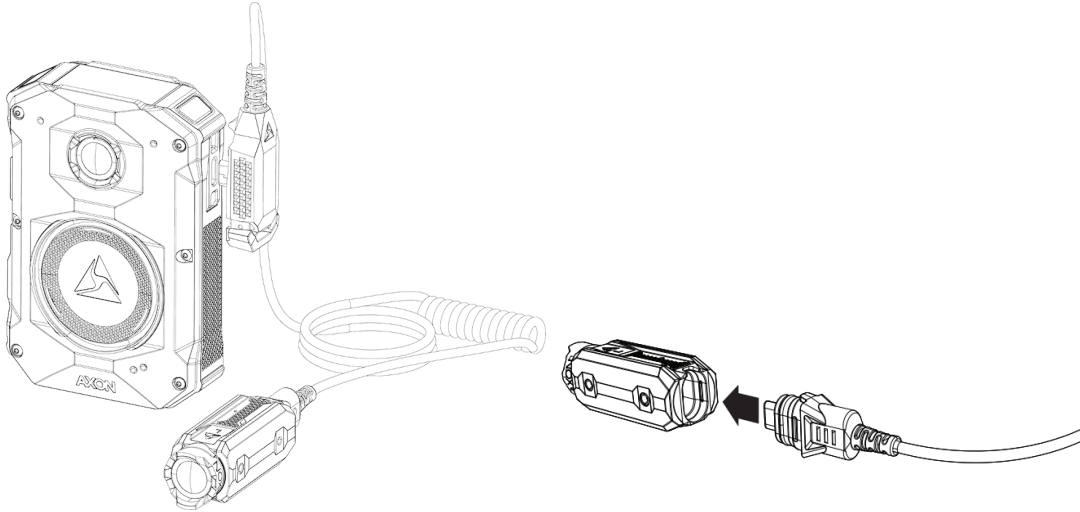

These cables are specifically calibrated to work with the Body 4 system. Use of unapproved cables will degrade system performance and may cause the system to malfunction.

Connect

In Axon Evidence, **Admin > Axon Body 4 > your profile** is a feature called **POV Auto-Rotation**. Leave this setting off for **manual** video orientation or toggle on for **automatic**.

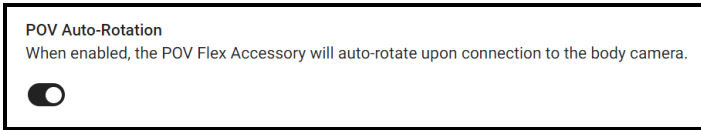

Manual orientation

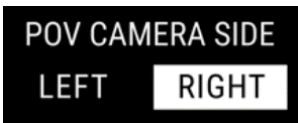

When you connect a Flex POV camera to a camera for the first time, it will prompt you to set the POV orientation to be either Left or Right.

Determine the orientation of the POV camera using the letter on the top of the POV camera when mounted.

Once set, update orientation using the camera menu: double-press **Select** and choose POV Orientation. You can also set orientation from the Axon View mobile app.

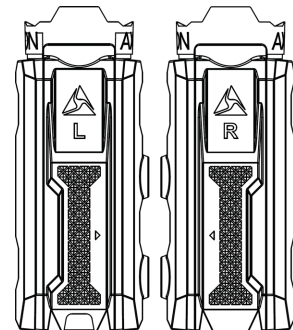

Automatic orientation

When you enable the POV Auto-Rotation feature in **Axon Body 4** settings, the Flex POV camera will set the correct orientation based on the position of the camera.

When the Flex POV camera connects to the body camera, the system evaluates and sets the orientation, displaying a brief confirmation message on the screen, like **POV CONNECTING RIGHT SIDE**. Orientation is normally set within 10 seconds, but the camera will continue trying for up to five minutes.

- If it can't detect the orientation within five minutes, it displays an alert and uses the default (or previously set) orientation.
- If you use the menu (double-press **Select**) to manually set POV orientation to right or left, this becomes the new default.

After the orientation is set within the first five minutes of connection, the auto-orientation process will not run again until the Flex POV camera is disconnected and re-connected again. If the camera becomes inverted for any reason (such as during a scuffle), it will not re-orient the image, keeping the user's true perspective.

Use the camera

Caution

With the Flex POV camera connected, don't wear the body camera vertically on the belt line; hanging vests and gear can impinge on and damage the cable connection, which may disable the POV camera. Recurring messages like "POV Not Detected, Try Reconnecting" or "POV Error, Contact Admin" indicate the cable may be damaged.

When the Axon Flex POV Camera is attached to the body camera, Body 4 will use the POV video sensor instead of the body camera's.

- If the POV camera is attached while buffering, the view will automatically switch from the body camera to the POV camera.
- If the POV camera is attached while recording, it will perform as follows:
 - Notify with four short haptic notifications and the message "POV CONNECTED WHILE RECORDING".
 - Ask you to "PRESS SELECT TO SWITCH TO POV".
 - After you press **Select**, Body 4 will end the recording on the body camera and start recording from the POV camera.

Note

If the camera is recording from the body camera while the POV camera is attached and no action is taken, it will continue to record from the body camera. This is intentional because since the system must stop recording on the body camera before starting on the POV, a moment of recording will not be captured. Leaving recording on the body camera ensures nothing crucial is lost in view transition.

Flex POV captures two audio tracks: a primary one from the Flex POV camera and a backup from the body camera.

Priority Upload

Priority Upload lets you wirelessly upload the most recent recording on your body camera to Axon Evidence using Wi-Fi or mobile data.

Watch this [video](#) for an overview of this feature.

Start a Priority Upload

Use Programmable Button 1

If your organization has **Upload Last Video** assigned to P1, double-press it. The camera vibrates and displays **UPLOAD STARTED**. No further user interaction is required.

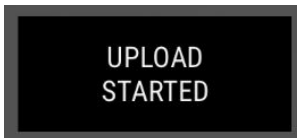

The display returns to its normal view of showing if the camera is **Ready** or **Recording**, along with the upload icon  at the bottom right.



Once the recording has uploaded, the camera vibrates, displays **UPLOAD COMPLETE**, and deletes it from the camera.

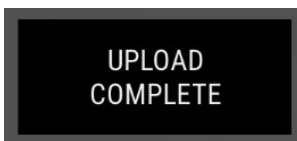

Your admin can change the behavior of the two programmable buttons. Learn more at [Programmable buttons](#) on page 9.

Use controls

1. Double-press **Select** to open the diagnostic menu.

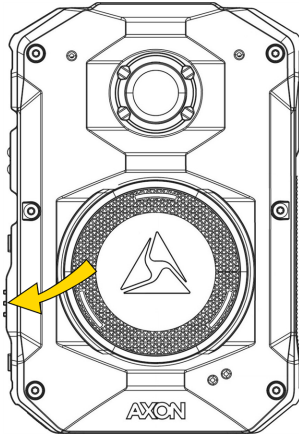

2. Press **Select** to select **Upload**.

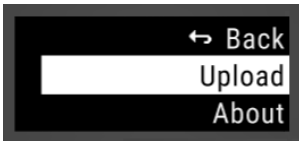

3. Select **Priority Upload**. If there is no recording on the device, the display shows **NO EVIDENCE**.



4. If there is a recording on the device, the top of the screen shows its start time followed by the duration in parenthesis. Use the volume buttons to select either **BACK** (upload nothing) or **START** (uploads the last saved recording), then press **Select**. You can only upload the most recent recording.



Once an upload has started, the display returns to its normal view of showing if the camera is **Ready** or **Recording**, along with the upload icon  at the bottom right.



The diagnostic menu option changes from **Upload** to **Uploading** when an upload is in progress.



Once the recording has uploaded, the camera vibrates, displays **UPLOAD COMPLETE**, and deletes it from the camera.

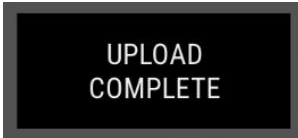

Cancel an upload

1. Open the diagnostic menu.
2. Select **Uploading**.



3. Select **CANCEL**.

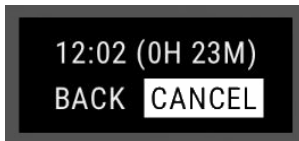

A message confirms the cancellation and the recording remains on the device.

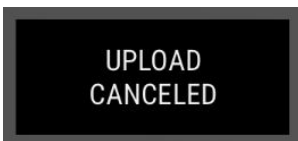

Error states and edge cases

Upload using mobile data may encounter the following errors.

Evidence exceeds upload limit

Recordings longer than 60 minutes cannot use mobile data due to the size of the file. Dock the camera or use View XL standalone mode.

Upload paused: poor signal

The camera pauses upload if it loses data coverage, displaying  at the bottom right. If coverage returns within 10 minutes, the upload will resume, otherwise it cancels and the recording remains on the camera.

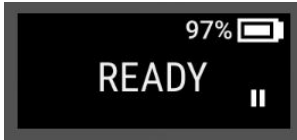

Upload paused: USB-C connected

A wireless upload pauses when you connect a USB-C cable. The upload will resume when you disconnect the cable.

Camera shut-down due to low battery

If the camera shuts down due to a low battery during a wireless upload, the upload pauses and the recording remains on the camera. The upload will resume when the camera is turned back on with sufficient charge.

Docked camera

If you dock your camera during a wireless upload, the upload will continue using the dock's ethernet connection, with the Priority upload occurring first.

Upload timed out

If the upload takes longer than two hours (which may occur if wireless coverage is poor and/or the file size is large), the upload pauses. Select to **RESUME** or **CANCEL** the upload.

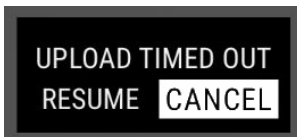

Upload paused: livestream

A wireless upload pauses  to allow a requested livestream. The upload resumes when the livestream ends.

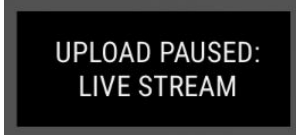

How Priority Upload affects the camera

Several factors can affect the performance, speed, and battery use of a wireless upload. With strong coverage, a 15-minute recording at 720p takes about five minutes to upload and uses about 2%, or 12 minutes, of battery capacity. With poor coverage, this same recording may use about 4%, or 24 minutes, of battery capacity.

The camera continues to buffer or record normally while uploading wirelessly.

Priority Upload is included as part of Axon Device Connectivity (included for any organization who previously purchased Respond or Respond+). Axon Evidence administrators can enable it by turning on the Priority Upload setting on the camera settings page under **Admin**:

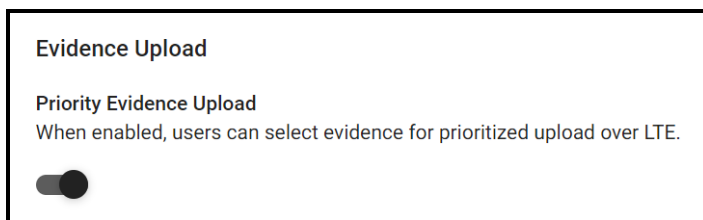

False Signal cancellation

False Signal cancellation lets you report a Signal event on your camera as false, which also marks the associated recording as a false detection. A false Signal recording can also be automatically categorized (see third setting in image below).

Follow your department guidance, but generally, don't take it upon yourself to determine whether Signal activations are false when interacting with members of the community. Only use this feature when no interaction occur, such as during Signal testing or when knowing the activation is 100% false.

You can't cancel a Signal event during a recording activated prior to the Signal event.

The **False Signal Cancellation** setting is disabled in Axon Evidence by default.

Signal

Signal Activation
When enabled, cameras can be activated by Axon Signal products. When disabled, cameras will not be activated by Axon Signal products.

False Signal Cancellation
When enabled, Signal alerts can be cancelled on the camera. Users can cancel a Signal alert by pressing the Select button.

False Signal Cancellation Default Category
The selected category is automatically applied to recordings cancelled as false activations.

1 Day Deletee ▾

Cancel a false Signal activation

If the camera is ready (buffering) and a Signal event occurs, it displays the Signal icon and activates recording. It then offers a 10-second opportunity to cancel the recording.



Press **Select** (between the volume buttons) within this time frame to cancel the activation and return the camera to Ready state (buffering).

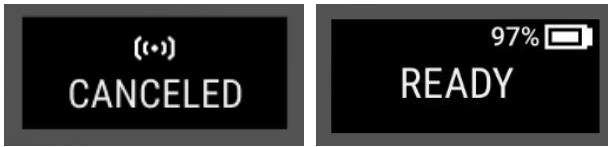

If you don't press **Select** within 10 seconds, the camera continues recording normally, but still displaying the Signal icon.



Automatic Wi-Fi upload

This feature lets cameras upload videos and update (download) firmware over Wi-Fi when an approved network is available. It is available for all camera users and requires no separate licensing.

This article describes how to set up a body camera Wi-Fi network, what happens on the camera during a firmware update over Wi-Fi, how to confirm an upload, what takes priority over Wi-Fi, and frequently asked questions (FAQs).

Your Axon Evidence administrator can enable this feature in the Admin section. Admins should also reference:

- [Enterprise Wi-Fi Network Quick Start Guide](#)
- [Personal Network Management](#)

Watch this [video](#) for an overview of Wi-Fi uploads with Body 4 cameras.

Advantages

When connected to an approved Wi-Fi network, a body camera will:

- Sync the clock once per day
- Sync changes made in the Axon Evidence camera settings page, including the list of approved Wi-Fi networks
- Upload recordings
- Download and install firmware updates

When connected to a dock, communication occurs over the wired connection (if available), even if Automatic Wi-Fi Upload is enabled. Wi-Fi communication halts whenever the camera is docked, whether it is networked or not, but will continue if charging through a USB-C cable.

Registration is the only non-supported Wi-Fi operation (use ViewXL Standalone or a networked dock).

In Axon Evidence

Set up a network

This section describes how to create an approved Wi-Fi access point that body cameras can use to upload recordings and download updates.

1. In Axon Evidence, select **Admin > Body Camera Wi-Fi Networks**.
2. Select **Add Network**.

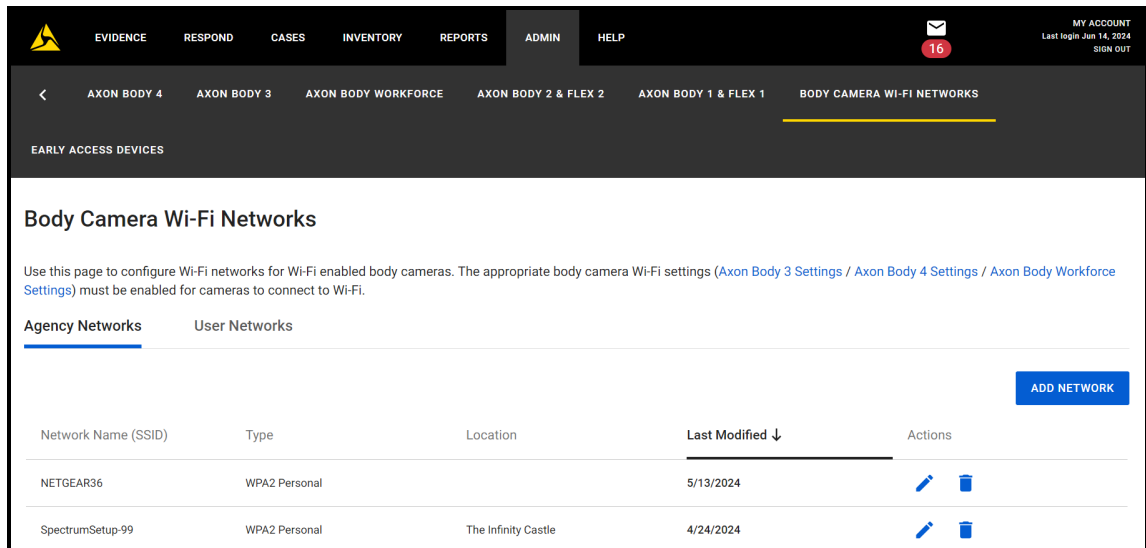



3. Enter the **Network Name (SSID)** and **Password**. Optionally, add **Location** information to differentiate networks with similar names.

The 'Add Network' modal form contains the following fields and sections:

- NETWORK TYPE ***: A dropdown menu currently showing 'WPA2 Personal'.
- Credentials**:
 - NETWORK NAME (SSID) ***: A text input field containing 'SSID'.
 - PASSWORD ***: A password input field with a masked view (dots) and a toggle icon to show/hide the password.
- Notes**:
 - LOCATION**: A text input field containing 'Location'.
 - A character count '0/100' is displayed at the bottom right of the location field.
- At the bottom, there are two buttons: 'CANCEL' and 'SAVE'.

Note While WPA2-TKIP, WPA, and WEP are supported, Axon recommends using WPA2-PSK networks for increased security.

4. Select **Save**.

5. Add more networks as needed.
6. Use **Edit**  and **Delete**  to manage existing networks.

Enable Automatic Wi-Fi Upload

1. Select **Admin > Axon Body 4**.
2. If applicable, select the appropriate profile.
3. Under **Evidence Upload**, toggle **Automatic Wi-Fi Upload** on.

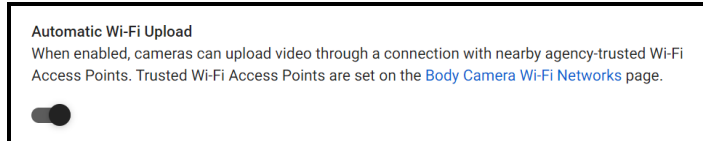

4. Scroll to the bottom and select **Save Profile Settings**.

Axon Body Cameras download updates to the network list the next time they are docked or can access an approved Wi-Fi network.

On the camera

What triggers Wi-Fi

These situations will cause the camera to communicate over Wi-Fi:



1. At the end of a recording. If multiple networks are available, it will use the one with the strongest signal strength. The camera checks for an approved network every 15 minutes.
2. If the feature is [disabled](#) (see page 53) and then re-enabled on the body camera.
3. When the camera is charging through a USB-C cable.

Wi-Fi communication will pause if the camera:

- Loses connection to approved Wi-Fi
- Stops charging via USB-C
- Drops below 20% battery
- Begins recording

Receive a firmware update over Wi-Fi

To receive a firmware update, the camera goes through the following steps.

1. The camera downloads the new firmware.
2. The camera displays **Wi-Fi**  when connected and **Download**  when downloading.

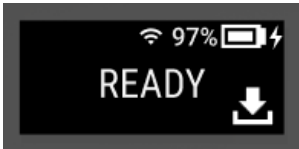

3. Once the firmware has downloaded, press **Select** (between the volume keys) at the opt-in prompt to install.

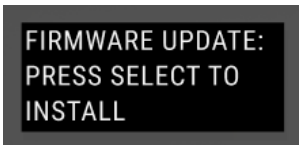

Note

Because this will restart the camera, don't install if the camera is in active use.

4. During installation, the LEDs flash white and the screen displays **Installing** .

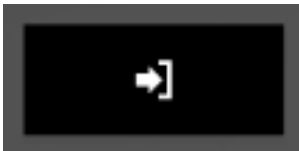

5. After installation, the camera restarts with the latest firmware.
6. If you ignore the opt-in prompt, it will disappear after 60 seconds and the camera will return to the Ready state.

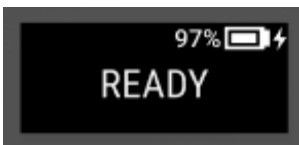

7. If the prerequisites for updating over Wi-Fi are still not met after four hours because the camera is in use, press **Select** to opt-out of (cancel) the installation.

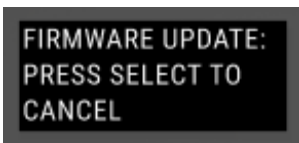

- If you don't cancel within 60 seconds of this message displaying, the firmware will install and the camera will restart as noted in step 4.

Disable Wi-Fi Upload on camera

If your network is overloaded or you have large recordings to upload, you may not want to upload wirelessly even though your admin has enabled it. You can disable wireless upload on your body camera:

- Double-press **Select** to open the diagnostic menu and use **Select** (between the volume keys) to choose **Upload**.



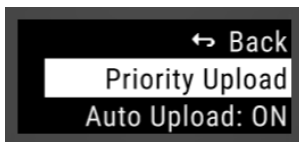

- If your organization has **Respond+** or the **Priority Evidence Upload** add-on, the first option listed will be **Priority Upload**. If not, it will be **Auto Upload** and whether it is ON or OFF.

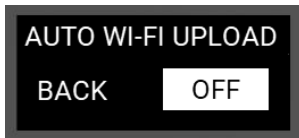

- To disable the Wi-Fi upload feature, select **Auto Upload** and then **OFF** using the volume buttons. To turn the feature back on later, return here and select **ON**. To cancel, select **BACK**.



- Once a camera connects to approved Wi-Fi and begins uploading, the screen displays **Wi-Fi**  and **Upload** .

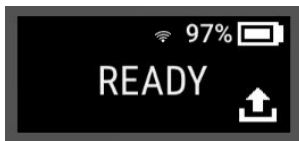

- When the upload completes, the camera vibrates and then deletes the recording from the camera.

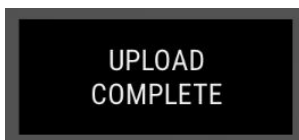

Check camera storage

Automatic Wi-Fi Upload makes wireless uploading, well, automatic. As long as you're within range of an approved Wi-Fi network, recordings upload and updates download. To confirm an upload, check the camera's storage menu.

1. Double-press **Select** to open the diagnostic menu.
2. Press **Volume Down ▼** to find **About** and select.
3. Move down and select **Storage**.

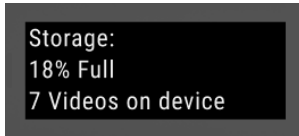

Wi-Fi and priority

In general, Wi-Fi communication will occur if the feature is on and an approved network is available, but other app or camera connectivity functions take priority.

- If a Wi-Fi network connection is lost or interrupted during upload, the upload pauses and resumes when reconnected.
- Wi-Fi connectivity to Axon applications such as Axon View or Fleet 3 Dashboard take priority over Wi-Fi communication.
- If you use Respond or Respond+, LTE connectivity for Respond-related activities take precedence over Wi-Fi communication. For example, if you start recording during a Wi-Fi upload, the upload will pause for livestreaming connectivity.
- Wi-Fi upload will not occur while recording to Wi-Fi or if already processing a Priority upload.

Frequently Asked Questions

If your question isn't answered here, contact [Axon support](#) or your Axon representative for more information.

How long must a camera be docked to receive an updated list of Wi-Fi networks?

Dock your camera or connect to View XL for at least two minutes to receive changes to settings, including Wi-Fi networks. An icon on the screen shows if it is downloading .

Do recordings wait to upload until they are tagged?

No. Recordings upload when connected to a networked dock or approved Wi-Fi network. After upload, they are deleted from the device and no longer visible or editable using Axon View, View XL, or Fleet Dashboard. You can edit recording metadata in Axon Evidence.

How does this feature affect battery charge?

The effect on battery is proportional to how often a camera is recording, the length of the recordings, and their resolution. It is similar to that of uploading recordings with ViewXL or Fleet Dashboard, both of which also use Wi-Fi connections. For example, a 15-minute recording at 720p High will use about 2% of battery to upload over a strong Wi-Fi connection.

What is the maximum Wi-Fi upload speed?

Up to 10 Mbps is possible, but dependent on many factors, such as what the network supports.

Will my camera download over Wi-Fi while in Sleep mode?

Yes, it will still check for an approved network every 15 minutes while in Sleep mode.

What happens if the opt-in or opt-out messages are interrupted by a different button press?

The message will disappear and the other action will take precedence. The camera will retry four hours later.

Will the camera upload and download over Wi-Fi at the same time?

Yes.

Video Recall

Video Recall adds a Video Recall tab to View XL Standalone Mode. The tab is only visible if your admin has assigned you to a role with the **Access Video Recall Files** permission enabled. Viewing videos through Video Recall is only available using View XL.

The Video Recall tab shows 30-minute-increment files captured in the past 18 hours while the camera was buffering, listed by time-stamp of the recording start time and duration of the file. If a recording is less than 30 minutes, it was interrupted by a different camera state, such as being in placed in Sleep Mode, docked, powered off, plugged in to View XL Standalone, or actively recording. When the camera returns to buffering, Video Recall recording resumes with a new file.

Files selected for upload in the Video Recall tab are placed in the Upload queue. You can't view Video Recall recordings or edit metadata prior to upload. View the status of the file uploads in the Upload tab. Once uploaded, the Video Recall recording functions as any normal recording in Axon Evidence.

Video Recall must be enabled prior to the event you want to recall for it to have captured that video. Your camera will not store, and therefore you can't retrieve, any buffered video prior to Video Recall being turned on.

Watch this [video](#) for an overview of using video recall.

Upload Video Recall recordings

1. Sign into View XL (download at Axon Evidence > **Help**), connect camera with a USB-C cable, and launch Standalone mode.
2. Select **Video Recall**.

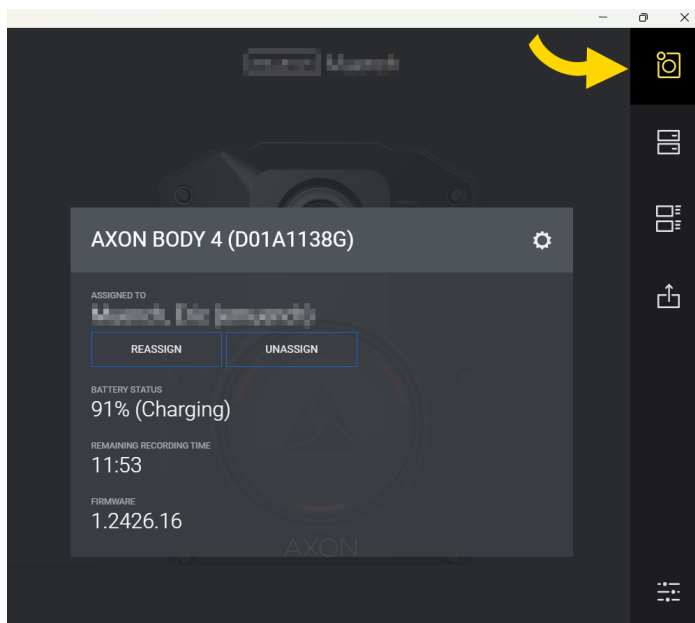

- The time-stamp shows the start time of the recording. Select **Upload**  to place a recording in the Upload queue. The file remains listed here until upload completes.

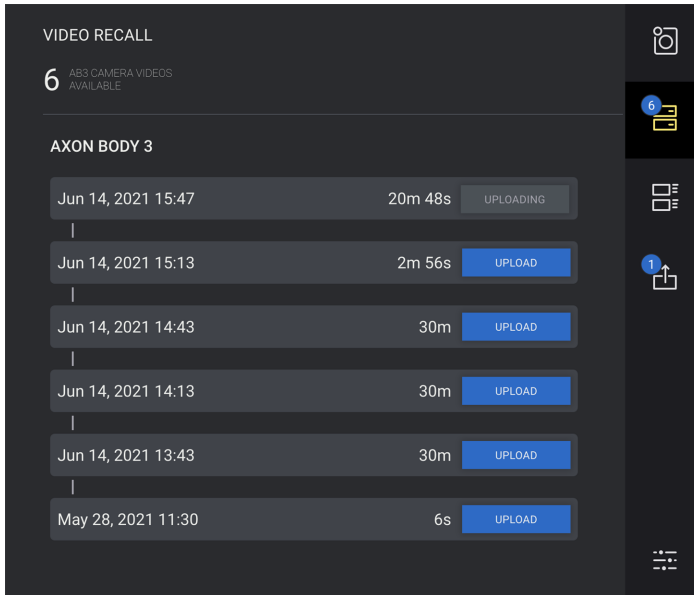

- Optionally, monitor the status of the upload in the **Upload Status** tab.

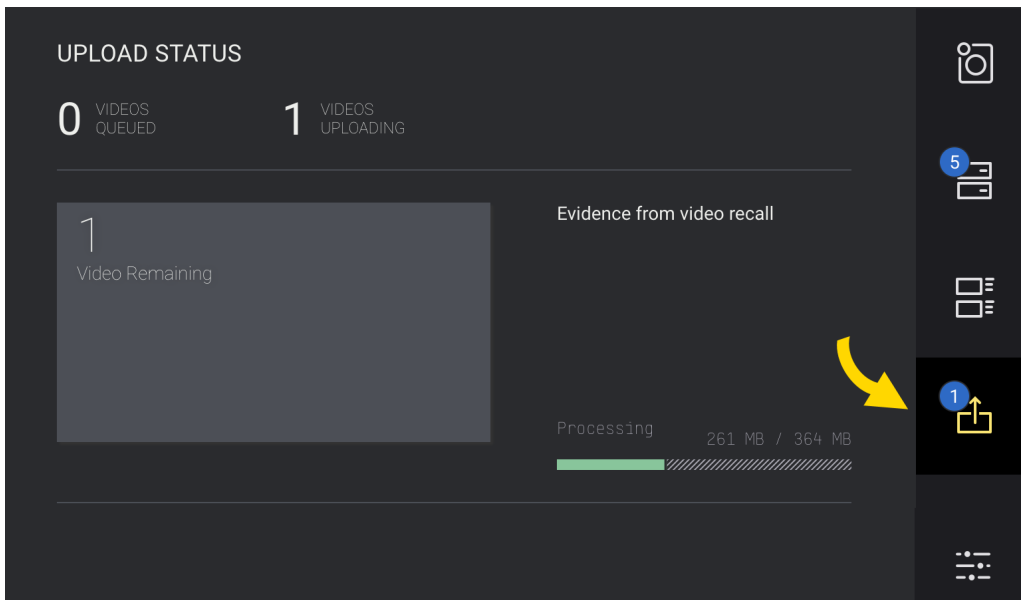

Video Recall recordings in Axon Evidence receive a unique tag in the watermark.

The screenshot displays the Axon Evidence web interface. At the top, a navigation bar includes 'EVIDENCE', 'RESPOND', 'CASES', 'INVENTORY', 'REPORTS', 'ADMIN', and 'HELP'. Below this, a secondary navigation bar lists 'ALL EVIDENCE', 'MY EVIDENCE', 'SHARED EVIDENCE', 'EVIDENCE MAP', and 'CITIZEN EVIDENCE'. The main content area features a video player with a title 'Video Recall - Axon Body 3 Video 2021-04-19 0942 X6039...'. The video player includes controls for 'DOWNLOAD', 'FLAG', 'REASSIGN', 'AUDIT TRAIL', and 'DELETE'. A yellow box highlights a watermark in the video that reads '2021-04-19 09:42:35 -0700 AXON BODY 3 XC03992YF VIDEO RECALL'. The video player also shows a 'Viewed by' notification: 'Viewed by [redacted] (vidence.com) on 13 Jun 2021'. To the right of the video player is a sidebar with 'Manage Access' (311 users), 'Manage Shares' (0 shares), and 'REVIEW ASSISTANT' (+ AUTO-TRANSCRIBE). The 'METADATA' section includes 'ASSIGNED BY: Rich, Eric (2660644282)', 'RECORDED ON: Apr 19, 2021 9:42 AM -07:00', 'UPLOADED ON: Apr 19, 2021 2:24 PM -07:00', 'UPLOADED BY: Rich, Eric (2660644282)', 'DELETION SCHEDULED FOR: Unscheduled', and 'FILE FORMAT: video/mp4'.

Icons, LEDs, and sounds

This section lists display icons, LED indications, and haptic feedback signals used by the camera.





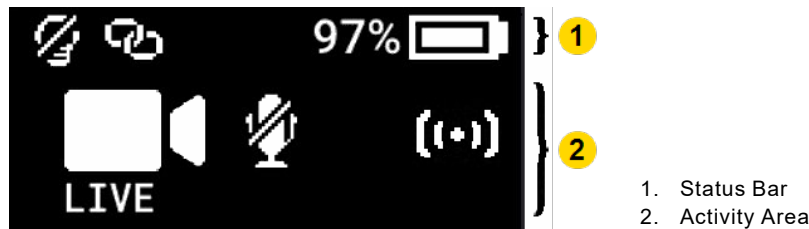

















Visual notifications

The display is divided into a Status Bar and Activity Area. Different information displays when the camera is in the field and in an Axon Dock. Some icons may not apply at your organization.



Icons during use















Status Bar Icon	Description
58%	Battery capacity
	Battery charging
	Battery not charging due to high temperature. The camera will continue to operate normally and resume charging when the camera cools down.
	Battery low ($\leq 10\%$); Operation LED blinks red
	Camera paired
	Lights off
	Moisture detected in the side POV port or bottom USB-C port. The camera will continue to operate normally, but ensure it is dry before docking or connecting a POV module.
	Stealth mode on

Activity Area Icon	Description	Operation LED
	Axon Respond Livestreaming*	 Blinking purple
	Axon Respond Voice Comms*	 Blinking purple
	Axon Respond Voice Comms, participants*	 Blinking red
L-READY or R-READY	Buffering with POV (right/left orientation)*	 Blinking green
STORAGE ALMOST FULL	Memory is 85% full	 Blinking red (while recording)
STORAGE FULL	Memory is 95% full	 Blinking red (recording stops)
	Mute mode	 Blinking blue
PAIRING	Pairing mode*	 Blinking blue
READY	Ready (Buffering) mode	 Blinking green (also Triad)
	Event (Recording) mode	 Blinking red (also Triad)
	Recording started by Axon Signal* broadcast	 Blinking red
	Recording with POV (right/left orientation)*	 Blinking red
	Sleep mode*	Off
n/a	Startup or shutdown	 Red
	Watch Me*	 Blinking red

* May not be enabled at your organization.

Icons and Triad LEDs while docked

The Triad LED on the front of the camera displays the camera's dock status.

Display	Description	Triad LED
58% 	Battery capacity	
	Battery charging – Triad LED colors show the charge level.	 Green: > 90%  Yellow: 11-89%  Red: <10%
DEVICE ERROR #	Device error #. Refer to the common codes in Troubleshooting on page 74 or the device page in Axon Evidence.	 Blinking red
Firmware v.1.15.0 Updated 8/18/2022	Firmware update complete – Displayed for 10 seconds after the update is complete and for 10 seconds after undocking.	 Spinning white during installation
NETWORK ERROR	Network error – Check network connection, see device page in Axon Evidence and troubleshooting instructions at help.axon.com .	 Blinking red and green
 15	Number of videos on camera	n/a
	Updating firmware or settings – Camera will resume normal operation after update. Operation LED solid white. Display may also show UPDATING.	 Spinning yellow
USERID123	User/Badge ID – Displays right after docking, when the camera is charging, for 10 seconds after undocking, and when no other activity is in progress.	n/a
 15/100 97%  18.2 Mbps 15% [1h 40m left]	Uploading video – Displays video being uploaded (here 15) of total on the camera (100), upload speed (18.2 Mbps), percentage complete (99%), and time remaining for the upload (1h 40m).	 Spinning yellow

Audible and haptic notifications

The camera emits audio prompts to notify you of device status. These prompts are accompanied by a vibration (haptic feedback). These prompts usually occur after you perform an action with the camera.

Operating Mode or Action	Audio Notification	Haptic Notification (vibration)
Axon Respond Livestreaming connected	Three short rising-pitch tones	One – long duration
Lights off	None	One – long duration
Low battery notifications at 10% and 5% battery capacity	Four quick high-pitch tones	Four – short duration
Marker captured	None	One – short duration
Mute mode, enter or exit	One short tone	Two – long duration
Pairing mode, enter	Three short rising-pitch tones	None
POV module connected/disconnected to body camera while buffering	One short tone	None
POV module connected/disconnected to body camera while recording	None	Four – short duration
Power off	Three short lowering-pitch tones	One – long duration
Power on	Two short rising-pitch tones	One – long duration
Recording reminder	Two short tones every two minutes	Two – short duration every two minutes
Recording start	Two short tones	Two – short duration
Recording stop, return to Ready mode	One long tone	One – long duration
Sleep mode, enter or exit	One short tone	One – long duration
Stealth mode, exit	None	Two – short duration
Voice comms session started	Four short tones	One – long duration
Volume up or down	One short tone at new volume level	One – short duration
Watch Me activated	Four quick medium-high pitch tones	None
Watch Me requested	Four quick high-pitch tones following by two-tones	Three – short duration

Axon View

The Axon View application lets you replay video and add metadata (title, case ID, and category) to your videos using a smart device. It also allows you to view the live feed of your camera while buffering or recording. It can't be used to alter or delete a video.

To use Axon View:

1. Download the Axon View application from your device's app store.
2. Install and open the Axon View app.
3. Follow the on-screen instructions or go to help.axon.com for additional information.

Note All data is stored on the Axon camera. No videos are stored on your smart device.

Go to the [Axon View](#) product page or see the Axon View for Devices User Manual for [Android](#) or [iOS](#) for details about using Axon View.

Watch this [video](#) for additional information about using Axon View with the Axon Body 4 camera.

Pair your camera with a smart device

For additional information on using Axon cameras with a smart device, see [Sign in and connect body camera](#) at my.Axon.

Note Internet access is required to pair the camera with Axon View. The security model for Axon View with the camera requires server login access when pairing and when the authorization on the camera expires (approximately every 10 days). Your admin must enable **Pair with Axon Applications** under App Support to pair with Axon View.

1. Turn on the camera.
2. Open Axon View, select your camera, and tap **Initiate Pairing**.
3. On the camera, press **Event** and **Select** simultaneously. You'll hear three short rising-pitch tones, the Operation LED blinks blue ■■■■, and PAIRING appears on the display.
4. Follow the Axon View on-screen instructions. Tap the serial number for your camera. When pairing is complete, live video appears in Axon View.

Axon View XL Standalone mode (Windows)

This camera can be connected to a Windows laptop or computer with Axon View XL to allow priority upload of videos from the camera to Axon Evidence and to charge the camera. Using View XL in standalone mode is separate from using it with Axon Fleet products.

Connect the camera to the laptop or computer with a USB C cable and use View XL standalone mode.

If your agency uses this feature, the administrator must set the appropriate Axon Evidence permissions to allow users to sign into View XL.

In Axo View XL, select Launch Standalone mode and then connect the camera to the computer. Use the normal View XL procedures to review recordings, add metadata, and upload recordings. For details on installing View XL and using Standalone mode, see [Body 4 and View XL Standalone Mode](#) on the [Axon Body 4](#) product page.

Admin settings

This section discusses camera settings available in Axon Evidence under **Admin > Devices and Applications > Body Camera > Axon Body 4 > Profile**. Not all settings may be applicable at your organization.

Video

Action	Definition
Quality	Determines the camera's recording quality.
Body Worn Camera Field of View	Determines the field of view of the camera. Setting this to 160 degrees will provide a wider field of view, while the 120-degree setting will provide longer battery life.
Flex POV Camera Field of View	Determines the field of view of the POV camera. Use of 120 degrees is recommended for longer battery life and most POV mounting positions.
Aspect Ratio	Determines the camera's video width-to-height ratio. A 4:3 video will capture more video in the vertical direction.

Watch these videos for additional information about these settings.

- [Configure video settings for Axon Body 4 cameras](#)
- [Configure Axon Body 4 camera settings](#)
- [Turn pre-event buffer on or off](#)
- [Flex POV module administration](#)

Pre-Event Buffer and Video Recall

Action	Definition
Pre-Event Buffer	Determines the buffer duration included in the final video.
Video Recall	Enables an 18-hour recording buffer. Users with the correct permissions can recall recordings from that buffer using the View XL Standalone app.

Watermark

Action	Definition
Watermark	Adds a permanent watermark with date, time, and camera serial number to the upper-right corner of videos.
Watermark Time	Sets the time standard/zone displayed in the recording watermark.
Watermark Audio Mute	When enabled, MUTED appears in the watermark when recording audio is muted by the user. The Users Can Mute During Recording permission must be enabled to configure this setting.

Audio

Action	Definition
Record Audio	Enables audio along with the video.
Pre-Event Buffer Audio	Enables audio in the pre-event buffer.
Audio in Video Recall	Enables audio in Video Recall recordings.

Lights

If enabled, lights can still be configured at the user level through Axon View or on the device.

Action	Definition
Front Light	Illuminates the front-facing Triad camera lights to provide a visible indication of recording status. The lights blink green during pre-event buffering, red when recording.

Location

Action	Definition
Location in Video	Enables gathering of location data from GNSS/GPS and embedding in video recordings.
Wi-Fi / Cell Tower Positioning	Enables gathering of location information from Wi-Fi access points and cell towers to improve location performance. This also improves battery performance.

Axon Respond

Configure permissions for using Respond features such as Livestreaming and Bi-directional Voice Communications in **Roles & Permissions**.

Action	Definition
Livestreaming	Determines when cameras can livestream audio and video to authorized organization users in Respond.
Camera Location on Axon Respond Map	Configures when camera location information is made available to the Axon Respond map.

Evidence upload

Action	Definition
Priority Evidence Upload	Allows users to select recordings for prioritized upload over LTE.
Automatic Wi-Fi Upload	Lets cameras upload video through a connection with nearby organization-trusted Wi-Fi access points. Set trusted Wi-Fi access points on the Body Camera Wi-Fi Networks page.
Rate-limited Camera Upload Speed	Sets the maximum upload speed in megabits per second for each individual camera.

Axon Signal

Configure assigned personnel activation in Axon Evidence under **Admin > Signal**.

Action	Definition
Signal Activation	Lets camera recording be activated by Axon Signal.
False Signal Cancellation	Lets Signal alerts be canceled on the camera by pressing Select .
False Signal Cancellation Default Category	The selected category is automatically applied to recordings canceled as false activations.

To learn more, watch this [video](#).

App support

Action	Definition
Pair with Axon Applications	Allows cameras to be paired via short-range wireless with Axon View, View XL (Fleet), and Fleet Dashboard. When disabled, cameras can still be connected via wired connection to View XL (Standalone).
Video playback in Axon Applications	Lets users play video still on the camera from Axon View, View XL (Fleet and Standalone), and Fleet Dashboard.
Axon Application Upload	Lets a user upload video from View XL (Fleet and Standalone) or Fleet Dashboard.

Battery

Action	Definition
Optimized Battery Capacity	<p>Limits the camera charge to approximately 90% of full capacity. While this reduces runtime, it improves long-term battery health and reduces degradation.</p> <p>Evaluate your battery needs in the initial weeks of deployment. For maximum runtime, disable this setting. If officers typically finish their shift with >25% battery life, enable this setting to increase the overall life of your batteries.</p>
Optimized Charging	Slows camera charging. While this increases charge time, it improves long-term battery health and reduces degradation. To charge the camera at the fastest rate, disable this setting.

To learn more, watch this [video](#).

Registration

Action	Definition
Automatic Camera Registration	When enabled, unregistered Body 4 cameras will automatically register to the same agency as the dock they are placed in. Requires the dock to be registered. Only applies to unregistered cameras. Will not affect cameras already registered. Generally, disable this setting once done registering cameras.

Firmware download

Action	Definition
Firmware Download Timeframe	Adjusts the timeframe in which cameras download a firmware update. A shorter timeframe means cameras download firmware sooner but may result in congestion on your network.

User permissions and mute configuration

Action	Definition
Users Can Mute During Recording	Lets users mute audio when recording an event. Push and hold mode requires a user to hold the mute button to remain muted. Static mode requires a user to manually enter and exit mute mode.
Users Can Use Stealth Mode	Lets users enable Stealth mode on their camera, which disables all lights, audio, and haptic feedback.
Users Can Adjust Indicator Light Settings	Lets users adjust the indicator light settings of their camera.
Users Can Use Sleep Mode	Lets users put their camera in Sleep Mode. Users starting a recording from sleep mode will lose the pre-event buffer. Signal products will not start a recording when a user is in sleep mode. A camera in sleep mode provides a haptic reminder every 15 minutes.
Sleep Mode Reminders for Users	Adjusts the frequency the camera provides reminders while users are in Sleep mode. Select from Off or 2, 5, 10, or 15 minutes.

Programmable buttons

Action	Definition
Programmable Button 1	Set to Sleep, Stealth, Upload Last Video, Watch Me, or No Function. Watch Me is enabled by default for Respond+ customers.
Programmable Button 2	Set to Select, Photo Marker, or Audio Mute.

Device management

Action	Definition
Settings return to default in dock	User settings return to default settings when the camera is docked.
On Camera Categorization	When enabled, a user will be prompted to add one or more Categories at the end of a recording and can select from the list of pre-configured Retention Categories configured by the agency.
High Resolution Photo Capture	When enabled, a user can capture high resolution photo captures while recording or buffering by pressing Select . Choose between Off , Recording only , and Recording and buffering .

Button confirmation

Action	Definition
End Recording Confirmation	Prevents unintentional ending of recordings. With Always , ending a recording requires a secondary confirmation press of Select after every recording. Auto only requires a secondary confirmation after recordings where Event was pressed in the middle of the recording.
Power Off Confirmation	Lets a single press of the power button bring up a menu with options for Power Off or Sleep (if enabled). Users must select the intended option and press Select to confirm. This prevents the camera from unintentionally powering off.

Care and maintenance

This section describes cleaning, charging, and storage for the camera.

Never disassemble the camera as this can compromise camera integrity and invalidate the warranty. The camera does not contain a memory card or any user-replaceable parts.

Follow all cleaning agent manufacturer directions.

Clean the camera

Watch this [video](#) for an overview of body camera cleaning for a Body 3.

Use a soft, damp cloth to clean the surface of the camera. Do not use harsh cleaners or solvents. Ideally, moisten the cloth with isopropyl alcohol.

Do not immerse the camera in water or cleaning solutions.

If the camera lens becomes dirty, use a lens blower brush to clean it and then wipe it with a soft cloth as needed.

If the camera display becomes dirty, clean with a damp cloth and dry with a soft cloth. Do not use ammonia-based or similar type window cleaners on the camera lens or display as these normally contain abrasives that can scratch.

Do not place the lens under running water or apply jets of water.

Do not use compressed air to clean the camera. Compressed air may damage the camera's microphones.

Ensure the microphone openings are clear of debris.

Charge the battery

Charge the camera battery by placing the camera in the dock or connecting a USB-C cable.

Note Ensure the USB port is dry and free of dirt and debris before placing the camera in a dock or connecting a USB-C cable.

The dock functions as an ethernet adapter, an unmanaged network switch, and charger. It charges and uploads video to Axon Evidence simultaneously.

When approximately 10% of the battery capacity remains, the camera display shows LOW BATTERY and the camera emits four quick tones and four short vibrations. These alerts repeat at 5% capacity.

Recharge a depleted battery as soon as reasonably possible.

Return cameras to Axon for battery replacement.



Watch this [video](#) for an overview of charging your camera.

Charge without a dock

To charge the camera when no dock is available, use a USB-C cable. You should still regularly place your camera in its dock to ensure it has the correct time synchronization and receives the latest firmware updates.

Charge your camera with any USB-C cable.

1. Connect the camera to the USB-C cable.
2. Connect the cable to a power adapter or USB port. A power adapter generally provides more charging power than a device's USB port.
 - If the camera was off, it enters low-power mode and the current charge level appears on the camera display. When you remove the cable, the camera turns off. During charging, power the camera on normally at any time and it enters Ready mode (buffering).
 - If the camera was on, it remains on with the charging icon beside the battery. When you remove the cable, the icon disappears and the camera remains on.

The color of the Operation LED on top provides a visual indication of the charge level. The LED is red  when the charge level is 10% or less, yellow  at 11–89%, and green  at 90% or higher.

Internal clock

Place your camera in an Axon Dock or connect it to View XL Standalone mode to update the camera's internal clock.

Update firmware

Return your body camera to its networked charging dock on a regular basis, ideally at the end of every daily shift. This will recharge the battery, upload data to Axon Evidence, and download and apply any available firmware updates. While docked, the Triad LED spins yellow  while downloading new firmware. Avoid removing the camera during a download.

Moisture

Don't charge your camera while the USB port on the camera or dock is wet. The camera will display a moisture icon if it detects moisture in the USB-C port.

If the USB port is wet, use a paper towel or absorbent cloth to blot the connector and then allow it to fully dry before charging.

If a camera is charging when it gets wet, remove it from the charging source (dock or cable), use a paper towel or absorbent cloth to blot the USB port, and then allow it to fully dry before charging again.

The USB port must be fully dry before placing the camera in a dock or connecting a cable.

It may take up to 15 minutes from the time you dry the USB-C port for the moisture icon to clear and the body camera to charge normally.

Camera storage

-04–95 °F -20–35 °C	Do not store Axon body-worn cameras in environments where the temperature is likely to be outside the maximum (such as under direct sunlight, near heaters, or in a vehicle in extremely hot weather) or minimum values.
70–75 °F 21–24 °C	For long-term storage, ensure room temperature is in this range and battery level is approximately 50% before powering down. Charge the stored camera back to around 50% once a year to prevent over-discharge of the battery. Do not store the camera fully charged or fully discharged.

Troubleshooting

Most issues with your camera can be cleared by restarting it. If you can't resolve your issue, contact your Axon administrator or Axon technical support at help.axon.com for additional support.

In this topic:

- [General FAQs](#)
- [Axon Dock FAQs](#)
- [Camera registration FAQs](#)
- [ADM error codes](#)
- [View camera information on the display](#)

General FAQs

What does the error code on my camera mean?

Error Code 1001 – There is an issue with the digital video recorder. Restart the camera and check if the issue resolves.

Error Code 1004 – There is an issue with the digital video recorder. Restart the camera and check if the issue resolves.

Error Code 1006 – There is an issue connecting with Axon Evidence for video uploads. It can be resolved by un-docking and re-docking the camera.

If you are still unable to resolve the errors, initiate an RMA (return merchandise authorization) to replace your device.

I don't see all the camera display icons in your diagrams, or some I used to see are gone now. What happened?

Some icons are for features that not all agencies have. Also, your administrator may have changed the camera display settings for your organization. Also, remember that different information displays when the camera is in the field and in its dock.

If you believe there is an error with your camera, try restarting it. If this doesn't resolve the issue, contact technical support at help.axon.com.

Why is my camera LED cycling through all the colors (blinking red, yellow and green)?

- Check if the camera display shows NETWORK ERROR. Check your network connection. Un-dock and re-dock your device and check if the error resolves.
- Restart the camera and check and check if the error resolves.
- Ensure the dock is registered.
- Refer to the camera's device profile page in Axon Evidence for additional error information.
- If none of the above work, contact technical support at help.axon.com.

I accidentally undocked my camera while it was updating firmware. What do I do?

No special action is needed, nor is your camera damaged. Avoid removing a camera from the dock while firmware is being applied, indicated by the Triad LEDs spinning white . But if it happens:

- If the camera was undocked when downloading the firmware, it resumes downloading the next time it's docked.
- If the camera was undocked while updating firmware, it continues updating until it is completed. Ensure the camera has enough battery power for the update to complete.

Important

Never power the camera off while firmware is being applied.

Why does Windows Media Player (WMP) keep playing the wrong audio track?

This is a known issue with WMP and dual-track media files. One solution is to select the other audio track in WMP, which is different for each version. Another is to use a different media player, like the free and open-source [VLC Media Player](https://www.videolan.org/vlc/) (Axon does not specifically approve use of any one media player).

How do I de-register a body camera from my organization?

An Axon Body 4 camera does not need to be returned to Axon to be de-registered. Contact technical support at help.axon.com.

Why is the buffer video length shorter than expected?

A recorded video may have a shorter buffer period than expected if:

- You started a recording shortly after turning the camera on, so the preconfigured buffer length has not yet elapsed.

- You ended one recording and started another before the preconfigured buffer length elapsed.
- The buffer is off or set to a different duration than expected in Axon Evidence.

Why can't I mute the video audio while recording?

This feature must be enabled in the Admin section of your Axon Evidence account. To use, see [Mute audio recording](#) on page 13.

Why is the time/date on my videos off?

See [Axon Camera Video Watermark Timestamp](#) for a discussion of how to set or disable time zone in a camera recording watermark and how timestamp works with Daylight Savings Time (DST).

Why don't my camera LEDs illuminate?

Your camera may be in Stealth mode. If an **S** icon appears on the display, press **Volume Up ▲** or **Volume Down ▼** for three seconds. The **S** icon disappears from the display and Stealth mode is canceled.

Why can't I add markers while recording?

This feature must be enabled in the Admin section of your Axon Evidence account. To use, see [Add markers while recording](#) on page 14.

Why can't I put my camera in Stealth mode?

This feature must be enabled in the Admin section of your Axon Evidence account. To use, see [Stealth mode](#) on page 13.

How do I view my live or recorded video in the field?

See [Axon View](#) on page 63.

How do I edit or delete a video on my camera?

You can't alter or delete a video before it's uploaded to Axon Evidence. You can use [Axon View](#) (see page 63), our mobile app, to view live camera video and add metadata such as title, case ID, and category. Videos deleted on Axon Evidence remain in a recycle queue for a period of time set by your organization.

How do I fix the Rapidlock stud and screw on my camera?

Check out this [video](#) covering Body 3.

Axon Dock FAQs

How do I ensure my dock is connected to the network?

If your dock is connected to the network, LEDs in the ethernet port blink green or amber. The camera will also be able to upload videos to Axon Evidence immediately upon docking.

My dock is registered, so why is "Device Profile" on Axon Evidence empty?

This is a known issue and a fix is in progress.

Why can't Axon Device Manager detect my dock?

When using this option, look for the NFC tag and hold your mobile device near the NFC icon on the dock. For the 1-bay dock, the icon is on the side of the dock nearest to the ethernet port. For the 8-bay dock, the icon is near bay 1, on the side of the dock near the power connection.

Alternatively, switch to the "Scan Code" tab in ADM and scan the 2D OCR code on the back of the dock.

Why can't I access my dock's Device Profile page on Axon Evidence?

Your dock must be registered to use the Device Profile page on Axon Evidence. See the **Axon Dock** PDF on your camera's [product page](#) or start with this online [Introduction](#) topic at my.Axon.

What comes in the box with my dock?

Each dock comes with an ethernet cable, 8-bay power cable and adapter (SKU 100142), and 1-bay power adapter (SKU 71104). See the **Axon Dock** PDF on your camera's [product page](#) or start with this online [Introduction](#) topic at my.Axon.

Camera registration FAQs

Why is my camera not fully charged when I power it on the first time?

Your camera ships partially charged as required by shipping regulations. Connect your dock (s) to the network and dock your camera to charge it. Always recharge a depleted battery as soon as reasonably possible using an Axon Dock. The Triad LEDs indicate charge level; see [Icons and Triad LEDs while docked](#) on page 61.

Why doesn't my camera display any status messages after being docked the first time?

- Your camera might be low on charge out of the box. Wait 10 minutes for the battery to charge.
- Ensure your dock has power.
- Remove your camera from the dock and re-dock it.

If none of these steps work, [initiate a return](#) with Axon to replace the camera.

How can I identify which camera failed preparation when multiple cameras are docked?

Check the serial number of the camera displayed in the error message by tapping **Errors**. The serial number is located on the back of the camera.

My camera displays NOT ASSIGNED after a successful registration. How do I assign a user to this device?

Assign cameras to users with [Axon Device Manager](#) (ADM) or through Axon Evidence.

To assign through Axon Evidence:

1. Ensure you have the correct permissions to assign users on Axon Evidence.
2. Select **Inventory**, then **Body Worn Cameras**.
3. Search for your device in the Body Camera search bar by the serial number.
4. Select the camera serial number in the list to go to the camera device profile page. In the Assignee section, select **Reassign**.
5. Enter the user's name and select **Reassign**.

ADM error codes

If there is a problem with preparing the camera, Axon Device Manager (ADM) displays an error.

Tap **Errors** to review the error information on ADM and refer to the following instructions to resolve the issue.

If you are unable to register any cameras, this may be due to a connectivity issue. See [Managing Network Allowed Lists with Axon Cloud Services](#) to ensure the appropriate network ports are open.

If some cameras are registering but others are not, this may be a transient error. A suggested general troubleshooting approach is to:

1. Start with only one camera docked at a time.
2. Attempt to register. If a registration error occurs, tap **Dismiss All** to allow ADM to retry registration.
3. If registration fails again, power the camera off and then on again and repeat the registration process.

Refer to these error codes and suggested actions:

Error Code	Description	Troubleshooting Action
-1	Communication to the camera has failed	<p>Power the camera off and back on, then retry registration.</p> <p>If attempting to register many cameras in close proximity, retry registration with individual cameras.</p> <p>If the error occurs again, tap Dismiss All and allow ADM to retry registration.</p>
33, -7249973, 43, or 49	Camera time is inaccurate	<p>Sign out and back into ADM.</p> <p>Power the camera off and back on, then allow the camera to remain docked for two minutes to allow sufficient time to synchronize the camera time.</p> <p>Confirm your organization network settings allow network communication from dock to Axon Evidence through port 80 and port 443. For details, see Managing Network Allowlists with Axon Cloud Services.</p>

Error Code	Description	Troubleshooting Action
45 or 47	Camera unable to reach internet	<p>Power the camera off and back on, then allow the camera to remain docked for one minute prior to retrying. It takes about 30 seconds to establish an internet connection. Tap Dismiss All and allow ADM to retry the registration.</p> <p>If the error persists after retrying to register several times, check the internet connection and troubleshoot the dock internet connection. Common connection issues include organization firewall settings.</p>
46	Camera unable to reach your organization's Axon Evidence account	<p>Sign out and back into ADM. If you can sign in, retry registration. Otherwise, contact technical support at help.axon.com to see if there are any issues with Axon Evidence.</p>
34, 48, or 50	Camera provisioning issue	<p>Power the camera off and back on, then retry registration.</p> <p>If the error persists, contact your Axon Evidence administrator to confirm that Device Management permission is enabled.</p> <p>If Device Management permission is enabled, contact your Axon representative or technical support at help.axon.com for assistance.</p>

View camera information on the display

View camera information such as serial number on the display using these steps:

1. Double-press **Select** to enter the device menu. The camera display shows five options: Upload, About, Cellular, Legal, and (if applicable) POV Orientation.
2. Use **Volume Up ▲** or **Volume Down ▼** to highlight **About**, then press **Select**. The camera display shows five options: Assignee, Device Config, Firmware, Serial, and Storage.
3. Use **Volume Up ▲** or **Volume Down ▼** to highlight the information you want to view, then press **Select**.
4. Press **Select** to return to the prior options.
5. Press **Event** to return to the normal camera display.

Technical information

Technical support

Visit help.axon.com for support options or call 800-978-2737.

Warranty

Axon Enterprise, Inc. warranty provisions are applicable on all Body system products. See www.axon.com/legal for detailed warranty information.

This warranty does not apply, and Axon shall not be liable for any loss, loss of data, damage, or other liability arising out of:

- a. Damage caused by failure to follow instructions regarding the use of the product;
- b. Damage caused by the use of non-Axon products or the use of cartridges, batteries or other parts, components or accessories not manufactured or recommended by Axon;
- c. Damage caused by abuse, misuse, intentional or deliberate damage to the product, or force majeure;
- d. Damage to a product or part that has been repaired or modified by persons not authorized by Axon or without Axon's written permission, or
- e. If any Axon serial number has been removed or tampered with.

Thus, any handling of the camera that alters the condition of the equipment by unauthorized personnel without proper technical training may result in the immediate loss of the manufacturer's standard warranty coverage by impacting the integrity of the equipment and rendering the quality testing performed by specialized technical personnel impossible after handling the equipment.

Warnings

For a full list of the warning associated with this product, see www.axon.com/legal.

Radio waves

The camera system transmission is in the frequency ranges of 2402–2480 MHz, 2412–2462 MHz, 5150–5350 MHz, 5470–5725 MHz, and 5725–5850 MHz. Additionally, depending on the model number and country, it may transmit in the frequencies listed below:



- AX1037: LTE B12 (699–716 MHz), LTE B13 (777–787 MHz), LTE B14 (788–798 MHz), LTE B26 (814–849 MHz), LTE B5 (824–849 MHz), LTE B4 (1710–1755 MHz), LTE B66 (1710–1780 MHz), LTE B2 (1850–1910 MHz), LTE B25 (1850–1915 MHz), LTE B30 (2305–2315 MHz), LTE B7 (2500–2570 MHz)
- AX1038: LTE B1 (1920–1980 MHz), LTE B2 (1850–1910 MHz), LTE B3 (1710–1785 MHz), LTE B4 (1710–1755 MHz), LTE B5 (824–849 MHz), LTE B7 (2500–2570 MHz), LTE B8 (880–915 MHz), LTE B20 (832–862 MHz), LTE B28 (703–748 MHz), LTE B40 (2300–2400 MHz)

FCC compliance statement

Changes or modifications to the equipment not expressly approved by the manufacturer could void the product warranty and the user's authority to operate the equipment.

Your wireless device (model AX1037) is a radio transmitter and receiver. It is designed and manufactured not to exceed the emission limits for exposure to radio frequency (RF) energy set by the Federal Communications Commission (FCC) of the U.S. Government. These limits are part of comprehensive guidelines and establish permitted levels of RF energy for the general population. The guidelines are based on standards that were developed by independent scientific organizations through periodic and thorough evaluation of scientific studies. The standards include a substantial safety margin designed to assure the safety of all persons, regardless of age and health. Before a device model is available for sale to the public, it must be tested and certified to the FCC that it does not exceed the limit established by the government-adopted requirement for safe exposure.

Axon equipment (models AX1037, AX1039, and AX1040) has been tested and found to comply with the limits for Class B digital devices, pursuant to part 15 of the FCC Rules. These limits are designed to provide reasonable protection against harmful interference in a residential installation. This equipment generates, uses and can radiate radio frequency energy and, if not installed and used in accordance with the instructions, may cause harmful interference to radio communications. However, there is no guarantee that interference will not occur in a particular installation. If this equipment does cause harmful interference to radio or television reception, which can be determined by turning the equipment off and on, the user is encouraged to try to correct the interference by one or more of the following measures:

- Reorient or relocate the receiving antenna.
- Increase the separation between the equipment and receiver.

- Connect the equipment into an outlet on a circuit different from that to which the receiver is connected.
- Consult Axon technical support for help.

Axon systems comply with part 15 of the FCC Rules. Operation is subject to the following two conditions: (1) This device may not cause harmful interference, and (2) this device must accept any interference received, including interference that may cause undesired operation.

ISED Canada compliance statement

This equipment (model AX1037) complies with the IC RSS-102 radiation exposure limits set forth for an uncontrolled environment.

Énoncé d'exposition aux rayonnements: Cet équipement (modèle AX1037) est conforme aux limites d'exposition aux rayonnements ioniques RSS-102 pour un environnement incontrôlé.

The device for operation in the band 5150–5250 MHz is only for indoor use to reduce the potential for harmful interference to co-channel mobile satellite systems.

Les dispositifs fonctionnant dans la bande de 5150 à 5250 MHz sont réservés uniquement pour une utilisation à l'intérieur afin de réduire les risques de brouillage préjudiciable aux systèmes de satellites mobiles utilisant les mêmes canaux.

Section 8.4 of RSS-GEN

Axon systems (models AX1037, AX1039, and AX1040) comply with Industry Canada License-exempt RSS standard(s). Operation is subject to the following two conditions: 1) this device may not cause interference, and 2) this device must accept any interference, including interference that may cause undesired operation of the device.

Systèmes Axon (modèles AX1037, AX1039, et AX1040) est conforme aux normes d'exemption de licence RSS d'Industrie Canada. Son utilisation est soumise aux conditions suivantes : 1) cet appareil ne doit pas causer de brouillage, et 2) doit accepter tout brouillage, y compris le brouillage pouvant entraîner un fonctionnement indésirable.

These digital apparatus (models AX1037, AX1039, and AX1040) comply with Canadian ICES-003 Class B. Digital apparatus model AX1026 complies with Canadian ICES-003 Class A.

Ces appareils numériques (modèles AX1037, AX1039, et AX1040) sont conformes à la norme canadienne NMB-003 Classe B. Appareil numérique modèle AX1026 conforme à la norme canadienne NMB-003 Classe A.

THIS AXON SYSTEM MEETS THE GOVERNMENT'S REQUIREMENTS FOR EXPOSURE TO RADIO WAVES.

CE SYSTÈME AXONE RÉPOND AUX EXIGENCES DU GOUVERNEMENT EN MATIÈRE D'EXPOSITION AUX ONDES RADIO.

Declaration of conformity and EU compliance statement

Axon declares that this Axon system is compliant with the requirements of the Radio Equipment Directive (RED) 2014/53/EU and the Electromagnetic Compatibility (EMC) Directive 2014/30/EU of the European Parliament and of the Council. A copy of the original Declaration of Conformity is at www.axon.com/legal.

- 8-bay dock (model AX1039) complies with EN 55032/CISPR 32 Class A
- 1-bay dock (model AX1040) complies with EN 55032/CISPR 32 Class B

Country of origin: Finished in the U.S. with U.S. and imported parts.

Compliance marks

Also see axon.com/legal/compliance-documentation.

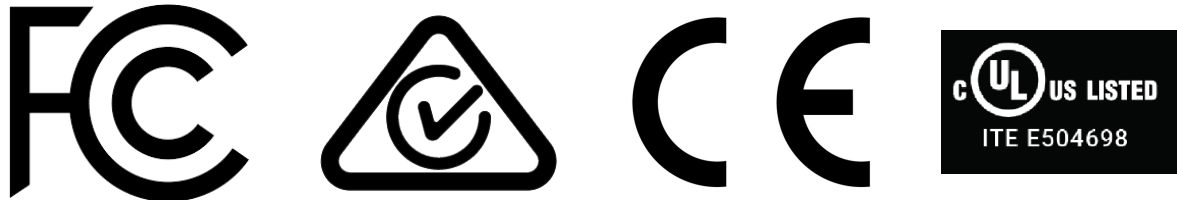

Korea:



1. 기자제 명칭(모델명) : LTE이동통신용무선설비의기기(육상이동국의 송수신 장치) (AX1038)
2. 등록번호 : R-C-CEW-AX1038
3. 적합성평가를 받은 자의 성명 : Axon Enterprise, Inc.
4. 제조년월일 : 2024/11
5. 제조자 및 제조국가 : Axon Enterprise, Inc. / 미국

R-C-QUT-EG065K-EA

R-NZ



“Este equipamento não tem direito à proteção contra interferência prejudicial e não pode causar interferência em sistemas devidamente autorizados.”

Labeling information

View camera information such as serial number on the display using these steps:

1. Double-press **Select** to enter the device menu. The camera display shows five options: Upload, About, Cellular, Legal, and (if applicable) POV Orientation.
2. Use **Volume Up ▲** or **Volume Down ▼** to highlight **Legal**, then press **Select**.
3. The camera display will automatically scroll the following information. Optionally, use **Volume Up ▲** or **Volume Down ▼** to scroll manually.

For model AX1037

- Model: AX1037
- FCC ID: X4GS01506
- IC: 8803A-S01506
- Contains FCC ID: X4GAB065
- Contains IC: 8803A-AB065
- ICES-3(B)/NMB-3(B)

For model AX1038

- Model: AX1038
- ANATEL ID: 02744-24-10342

4. Press **Event** to return to the normal camera display.