





Axon Fleet 2 System Overview

Document Revision: A
February 2020

Microsoft and Windows are trademarks of Microsoft Corporation registered in the US and other countries.

Cradlepoint is a trademark of Cradlepoint, Inc.

  Axon, Axon Evidence, Axon Fleet, Axon Signal, and Axon View XL are trademarks of Axon Enterprise, Inc., some of which are registered in the US and other countries. For more information, visit www.axon.com/legal.

All rights reserved. ©2020 Axon Enterprise, Inc.

Table of Contents

- Introduction 4
 - Axon Fleet 2 Standard Hardware Kit 4
- Getting Started – Requirements 6
 - Axon Evidence 6
 - MDT 7
 - System Requirements: 7
 - Firewall and Antivirus Configuration 8
 - Additional Reading..... 8
 - Router/Network 9
 - (Optional) Wireless Offload Server 10
 - Additional Reading:..... 10
 - Vehicle 11
 - Additional Reading:..... 11

Introduction

The Axon Fleet 2 solution is a camera system incorporating an audio and video recording device. This system is designed for use in tough environmental conditions encountered in law enforcement, corrections, military, and security activities. The Axon Fleet 2 system is designed to record events for secure storage, retrieval, and analysis using Axon Evidence (Evidence.com) services. The recorded events can be transferred wirelessly to the Axon Evidence website through Wi-Fi technology. You also can transfer information by using Evidence Sync software installed on a Windows computer. The Axon Fleet 2 system consists of up to 2 cameras: one installed in the front of the vehicle in a windshield mount, and the second pointed at the law enforcement vehicle's prisoner compartment. The Axon Fleet 2 system cameras have 2 operating modes designed to accommodate the needs of law enforcement, corrections, security, and the military. The default mode, or BUFFERING mode, provides pre-event buffering to capture activities that occur prior to activating cameras, and EVENT mode, which records events. If the Axon Fleet 2 system is used in an emergency vehicle equipped with an Axon Signal Vehicle unit, the camera will transition from BUFFERING to EVENT mode when an appropriate event occurs (such as your emergency vehicle's light bar being activated). The camera is normally powered by the vehicle. If the vehicle's ignition is shut off, an inline Axon Fleet power unit provides power for up to 4 hours of recording when fully charged.

Axon Fleet 2 Standard Hardware Kit

1x Axon Fleet Front Camera System | mount | power unit | power unit harness

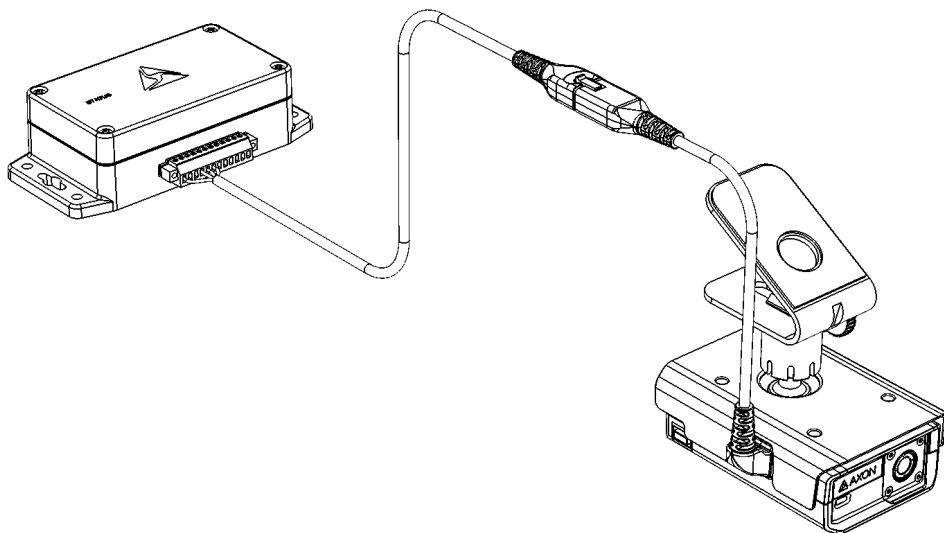

1x Axon Fleet Rear Camera System | controller | mount | power unit | power unit harness

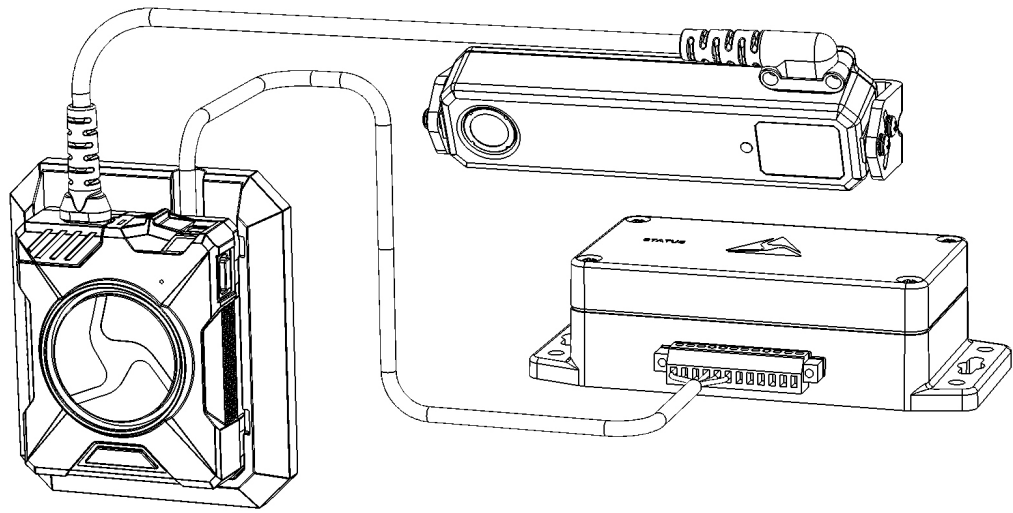

1x Axon Signal Vehicle

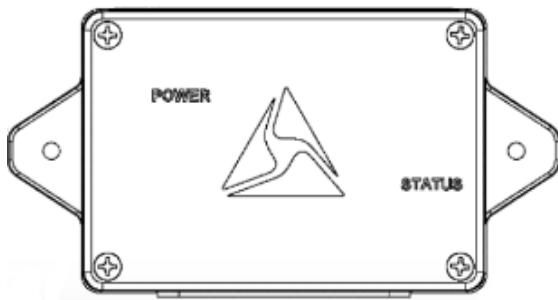

1x Bluetooth USB dongle

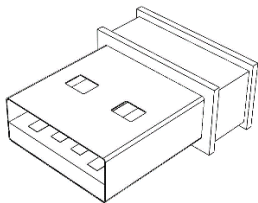

1x CAT6 Ethernet Cable for router to MDT

1x Axon View XL Software

2X Ferrite Clamp

The following images show the Axon Fleet 2 components and tools, and the general installation layout of Axon Fleet 2 components and wiring in a vehicle.

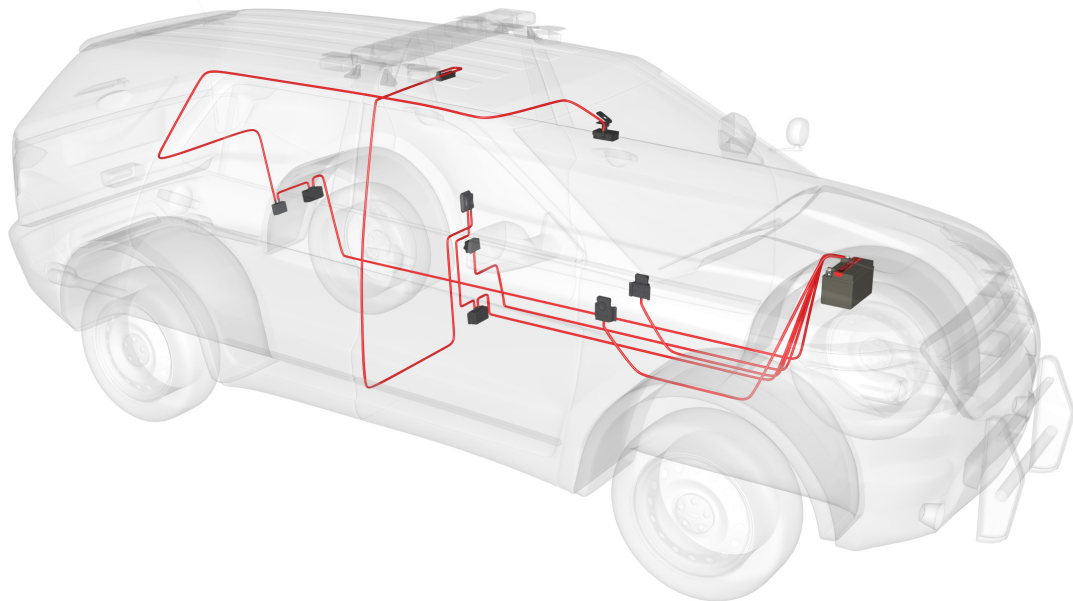

Getting Started – Requirements

Axon Evidence

The Axon Fleet 2 system leverages the Axon Evidence.com platform to provide a cloud-connected in-car video solution. Axon Enterprise, Inc. (Axon) has developed the Axon Fleet 2 system and Axon Evidence.com solution for use by law enforcement. Depending on agency need, the solution can provide video capture, secure digital media storage and management, and paperless tracking and reporting. This unique system is suitable for both smaller

agencies lacking in resources or large agencies trying to streamline and become more economical.

An administrator account is created for every agency on Axon Evidence.com during the initial implementation cycle of Axon Evidence. Typically, the person most responsible for your Axon Evidence.com agency owns the first administrator account. The first administrator usually defines security settings, creates custom roles and permissions, adds users, creates categories and sets retention policies, and configures several other administrative features of your Axon Evidence agency account. Please Note: Your agency must have an Axon Evidence account for Axon Fleet 2 to operate. Appropriate device administration permissions must be enabled to allow vehicle configuration.

Licenses are required for Axon Evidence access and each user must carry an active user license to login to Axon View XL and operate the Axon Fleet 2 system.

Each vehicle must be configured in Axon Evidence before the Axon Fleet 2 system will operate. For detailed instructions on how to configure vehicles, see [Axon Fleet Evidence.com Set-Up Guide](https://www.axon.com/axon-fleet-evidence.com).

MDT

Axon Fleet leverages the vehicle's mobile data terminal (MDT) to run software (View XL) that allows the user to review, tag, and initiate the upload of videos recorded on the cameras. View XL identifies and pairs with the in-car components using the Fleet Bluetooth dongle. Once paired over Bluetooth, View XL prompts the cameras to connect to the in-car router's 5GHz Wi-Fi network.

Please Note: Each vehicle equipped with the Axon Fleet system must have an MDT to facilitate wireless evidence offload, settings changes, and updates. Removing or powering off the MDT will interrupt evidence upload.

System Requirements:

Operating System: Windows 7 or 10 required.

Disk Space: 25GB or more

Memory (RAM): 8GB or more

Open USB Ports: 1 USB 2.0/3.0

- USB Port is powered at all times.

See USB Dongle Power Management - Help Center Article

Available Ethernet Ports: 1

- Ethernet Port is powered at all times.

Note: Connection on Mobile Docking Station (if applicable) is preferred

Axon View XL is installed and updated to the latest version.

Note: Axon View XL Installation requires MDT Admin permissions.

MDT can access Axon Evidence (Evidence.com)

Firewall and Antivirus Configuration

Open Ports

- TCP 7777, 7878 (local loopback, agent to/from HUD communication)
- UDP 10110 (configurable, GPS)
- UDP 5004 - 6004 RTSP (Live View)
- Port 443 outbound (Access to Axon Evidence (Evidence.com))
- TCP 80 (HTTP) outbound to camera
- TCP 554 (RTSP) outbound to camera

Allows access to the following Axon Evidence External IP Addresses:

- 52.227.178.220
- 52.227.176.143
- 52.227.180.79
- 52.227.177.17
- 52.227.170.136
- 52.227.173.38

Additional Reading

[Axon View XL Operations Guide](#)

[Axon Fleet 2 Camera Quick Start Guide](#)

Router/Network

Axon Fleet requires an in-car, wireless router to facilitate communication between the cameras and the MDT, provide GPS functionality, and an LTE connection. The in-car router's primary function is to host the 5GHz access point that the cameras require to connect to the vehicle's local network. It also provides View XL with GPS information that is applied to video in the form of metadata and used to facilitate Fleet's speed trigger. The router should also be able to act as the vehicle's primary source of WAN access through the use of an LTE SIM card.

It is recommended that the router has LTE service.

- Agencies using an APN may require special configurations, including network firewall exemptions for Axon Evidence.

The MDT should be connected to the router via Ethernet.

The Axon Fleet cameras require DHCP.

The Axon Fleet cameras require 5GHz Wi-Fi with a 20MHz channel width.

Each vehicle requires a unique SSID with WPA2-Personal security.

The router must provide GPS (TAIP or NMEA) over the local network using UDP 10110.

For Wireless Offload Server option, the router must be capable of Wi-Fi as WAN.

Remote management capabilities are recommended.

The in-car network should be exempt from any VPN to allow network traffic between View XL and cameras.

For configuration details, see [Axon Fleet Network Configuration Guide](#) and [NetCloud Configuration Guide](#).

Axon Fleet Network Architecture - LTE Offload

Port	Protocol	Description
80	TCP	Webservice API
554	RTSP	Local live view / video preview server
5004 - 6004	UDP	Local live view for axon-agent.exe
443	HTTPS/TLS	Outbound to Evidence.com for Authentication
10110	UDP	GPS

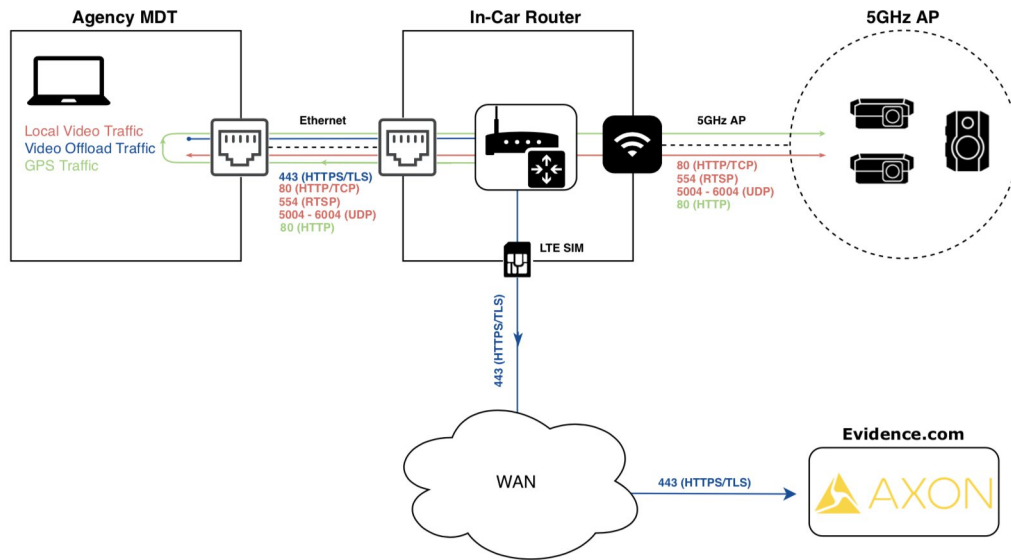

(Optional) Wireless Offload Server

As part of the Axon Fleet 2 solution, Axon offers an optional offload method with an on-premises server. When a vehicle enters the range of a Wi-Fi access point, Axon View XL recognizes the offload server and begins to offload videos from the Axon View XL upload queue to that server. Videos from the offload server are then sent to Axon Evidence (Evidence.com). The video offload is done in segments, but as with LTE offloads, the video file is retained on the Axon Fleet camera until confirmed receipt to Axon Evidence.

An agency must be pre-qualified by Axon before implementing this method as it requires additional configuration and infrastructure for operation.

Additional Reading:

Wireless Offload Server Setup

Vehicle

The Axon Fleet 2 system is designed for use in emergency vehicles of various types, including: sedans, SUVs, and trucks. All components of the fleet system must be enclosed within the passenger compartment or trunk. The system is not designed for marine use.

Constant Power Voltage: 9V - 18V | Nominal 12V

Key ON Voltage (Ignition Wire): 6V - 18V | Nominal 12V

Key OFF Voltage (Draw): 30mA

Chassis Ground: Impedance 0Ω - 0.25Ω

Recommendation: Use dedicated ground buss bars or connect directly to the chassis.

- Do not use a floating ground.
- Do not use a ground path that may be compromised by vehicle shock and vibration.
- Distance from System Ground to High Current Load: >12 in.

Examples of High Current Load: UHF/VHF radios or any device consuming more than 1A.

Do not use ground path shared with UHF/VHF radios.

Additional Reading:

[Axon Fleet 2 Installation Guide](#)

[Axon Fleet 2 Camera Quick Start Guide](#)

[Axon Help Center Online Knowledge Base](#)

[Cradlepoint Online Knowledge Base - Axon](#) (router information)